



WESTCAR s.r.l.

ROTOFLUID

ENGLISH

FLUID COUPLINGS





WESTCAR PRODUCTS

ROTOFLUID hydraulic couplings for rated power up to 4000 kW



ROTOGEAR tooth gear couplings for torques up to 383.000 Nm

ROTOFLUID GGG hydraulic couplings (with cast-iron casing) for rated power from 100 to 6000 kW



ROTOFLEXI® flexible couplings with quick replacement of the rubber element without axial hubs movement. For torques up to 4.000 Nm.

ROTOFLUID-SCF/DCF hydraulic couplings with simple/double delay chamber

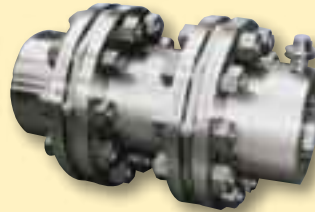
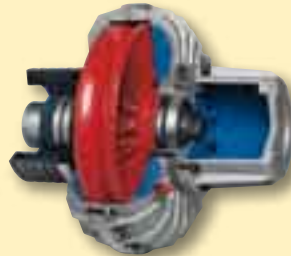

HBX – GCX – HPX disc couplings. With spacer HBSX – GCSX – HPSX - BE. Torques up to 1.043.300 Nm

ROTOFLUID-CA hydraulic couplings with annular chamber and starting torque lower than nominal motor torque

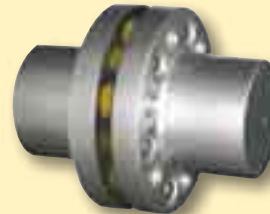

ROTOPIN flexible couplings with pins and buffers axially sliding. For torques up to 300.000 Nm

Drum and disc brakes with brake servo

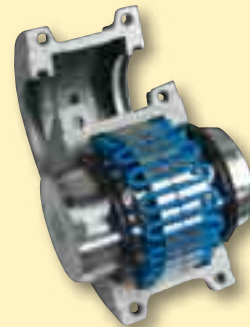

ROTOGRID flexible taper grid couplings. For torques up to 169.500 Nm

SOFTSTART
Static starter with digital control for rated power up to 750 kW.
Energy saving function.
Water hammering control.
Programming also via RS 485



ROTOMECH hydromechanical couplings with hydraulic start-up and centrifugal mechanical lock-up with zero slip at running. For rated power up to 1500 kW



ON REQUEST, ATEX CERTIFIED PRODUCTS CAN BE SUPPLIED.

TABLE OF CONTENTS	PAGE
Operating principles and features of ROTOFLUID couplings	2
Electric motor characteristic curves with and without fluid coupling	3
Fluid couplings with delay chamber	4
Characteristic starting curves	5
ROTOFLUID coupling selection diagram	6
ROTOFLUID coupling selection table for 50 Hz, 60 Hz UNEL MEC electric motors	7
Performance calculation	8-9
ROTOFLUID couplings moments of inertia	10
ROTOFLUID ALFA - coupling for in line versions	11
Installation options	12
ROTOFLUID selection with recommended flexible coupling for standard electric motors	13
Table ROTOFLUID ALFA "K"	14
Table ROTOFLUID ALFA "SCF K"	15
Table ROTOFLUID ALFA "DCF K"	16
Table ROTOFLUID ALFA "K-S" "SCF K-S" "DCF K-S"	17
Table ROTOFLUID ALFA "K-LRV" "SCF K-LRV" "DCF K-LRV"	18
Table ROTOFLUID ALFA "K-LRU" "SCF K-LRU" "DCF K-LRU"	19
Table ROTOFLUID ALFA "K-FRV" "SCF K-FRV" "DCF K-FRV"	20
Table ROTOFLUID ALFA "K-FRU" "SCF K-FRU" "DCF K-FRU"	21
Table ROTOFLUID ALFA "K-AB" "SCF K-AB" "DCF K-AB"	22
Table ROTOFLUID ALFA "K-FRD" "SCF K-FRD" "DCF K-FRD"	23
Table ROTOFLUID ALFA "K-AFF" "SCF K-AFF" "DCF K-AFF"	24
Table ROTOFLUID ALFA "K-FR-PAV" "SCF K-PAV" "DCF K-PAV"	25
Table ROTOFLUID ALFA "KK" "SCF KK" "DCF KK"	26-27
Brake drum "FP" for ROTOFLUID ALFA "KK"	28-29
Table ROTOFLUID ALFA "WAG" "SCF WAG" "DCF WAG"	30
Table ROTOFLUID ALFA "WAG-G" "SCF WAG-G" "DCF WAG-G"	31
Table ROTOFLUID ALFA "CK-LRS"	32
ROTOFLUID coupling ALFA "K-SS"	33
ROTOFLUID BETA - coupling for pulley versions	34
Mounting examples with ROTOFLUID couplings BETA pulley versions	35
Table ROTOFLUID BETA "X"	36-37
Table ROTOFLUID BETA "J"	38-39
Table ROTOFLUID BETA "H"	40
Table ROTOFLUID BETA "Z" "ZI"	41
Bore dimensions table for ROTOFLUID coupling	42
Bore dimensions for flexible coupling and brake drum hubs	43
ROTOFLUID coupling instructions for replacement and variation of the oil quantity	44
ROTOFLUID coupling scf / dcf instructions for replacement and variation of the oil quantity ..	45
Fusible Plug	46
Thermal trip plug	47
Electric - thermal - switch equipment type "ET"	48
Electronic "scd" device for overload control	49
Instructions for mounting rotofluid coupling on the motor shaft	50
Instructions for pulling off rotofluid coupling from the motor shaft	51
Screw puller "VE" type - pulling off system "SE" type	51
ROTOFLUID couplings outline and main components	52
Recommended spare parts	53
Optional functions	54
Application requirements	55
Fields of application	56

INDEX OF TECH SHEETS

10-137A**	2
10-002B**	7
10-013A**	44
10-016A**	45
10-019D**	42
10-023A**	43
10-030A**	8
10-031A**	9
10-035A**	10
10-040A**	13
10-047A**	34
10-052A**	56
10-057B**	11
10-059A**	55
10-060A**	54
10-061A**	3
10-080A**	5
10-100A**	6
10-138A**	12
10-141A**	4
10-142A**	35
40-010B**	14
40-050A**	33
40-280A**	32
45-042B**	18
45-020B**	17
45-043B**	19
45-060B**	20
45-062A**	21
45-066B**	25
45-070B**	23
45-081B**	22
45-082B**	26
45-083B**	27
45-092B**	24
45-112B**	30
45-113D**	31
45-204A**	41
45-210A**	38
45-211C**	39
45-220A**	40
45-250A**	36
45-251B**	37
50-010B**	16
52-006B**	15
70-006B**	28
70-007B**	29
80-002A**	46
80-003A**	47
80-004A**	48
80-022A**	49
90-004A**	50
90-005A**	51
90-018A**	52
90-022A**	53

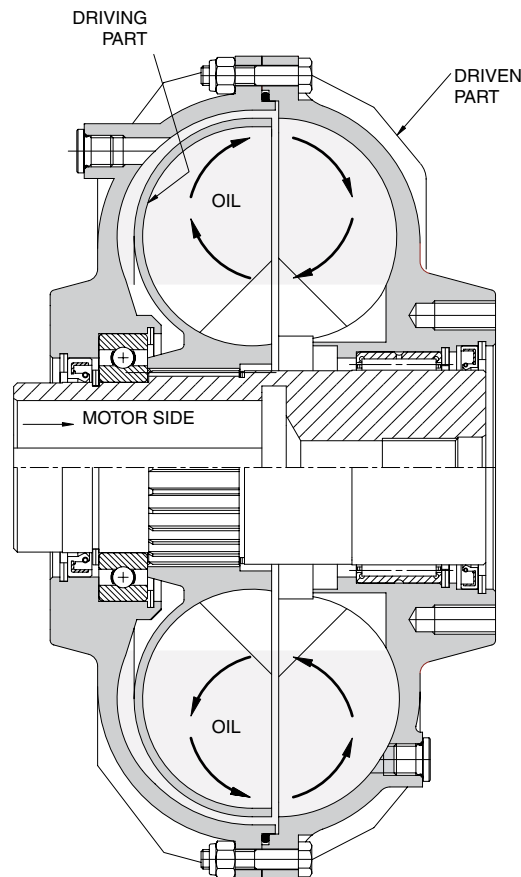

The ROTOFLUID fluid coupling is designed to provide your plant with optimum reliability and durability. It is fitted between the motor (drive) and machine (driven component).

The ROTOFLUID fluid coupling comprises basically two impellers, with radial blades, opposed to each other, one connected to the motor shaft and the other to the input shaft of the Driven Equipment or Machine.

The ROTOFLUID fluid coupling acts like a centrifugal clutch, by driving an impeller, the oil passing from the blades to the driven part, which acts as a driven impeller, transmits the power to the Equipment or Machine. The oil, which fills the fluid coupling, transfers the torque and also lubricates moving parts.

Fluid couplings are the easiest and cheapest way of creating a perfectly Flexible Drive Train, because no mechanical parts are necessary between the motor and the Equipment or Machine being driven.

Without mechanical parts, there is practically no wear.

Losses in the fluid coupling become power drops according to the following formula:

$$S\% = \frac{n_m - n_u}{n_m} \times 100$$

where:

n_m = motor speed in rpm

n_u = output speed from the fluid coupling in rpm

The elasticity of the fluid coupling solves problems of power peaks in conventional electric motors and the machines they drive.

THE ADVANTAGES OF USING FLUID COUPLINGS

- easy start-up with gradual acceleration of the driven component
- automatic load speed adjustment on the basis of the synchronous speed of two or more motors
- the drive train is protected against overloads
- rotational vibrations are dampened
- the torque transmitted complies with pre-set values
- direct on-line start electric motors can be used, without star-delta starters or slip-ring motors with rheostat

FITTING A ROTOFLUID FLUID COUPLING GIVES YOU THE FOLLOWING BENEFITS:

- a large range of accessories
- interchangeable accessories on the basic cell
- the dimensions of the shaft-pulley system are perfectly suited to the needs of the drive train
- all fluid couplings that utilise a belt drives, from Size 40P up, are fitted with ball bearings under the pulley to guarantee above-standard radial loads
- all the fluid couplings used for Horizontal applications are fitted with ROTOFLEXI Elastic Flexible coupling, which gives the advantage of, the user, of being able to replace the Flexible element, by removing it radially from the coupling, without either disturbing the Motor or the Driven Equipment or Machine

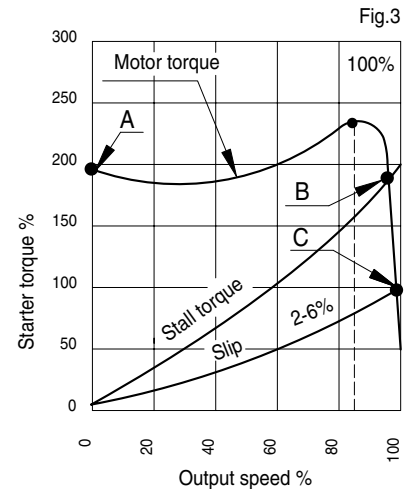
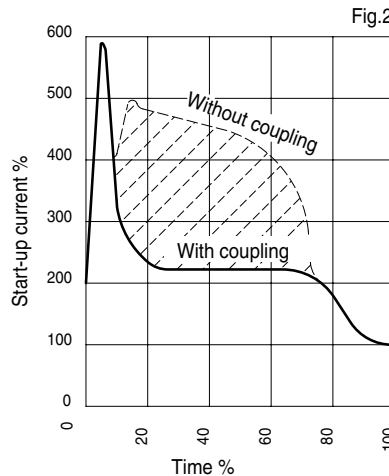
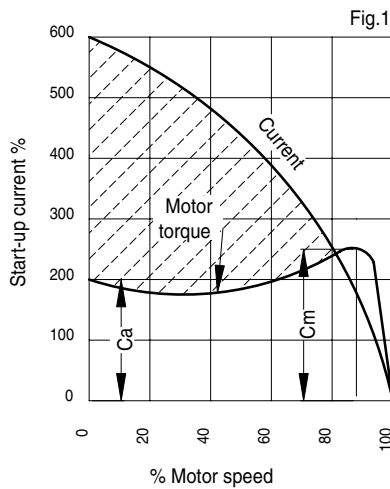

START-UP WITHOUT FLUID COUPLING

Figure 1 represents the typical start-up of an electric motor directly coupled to the load. The dotted line represents the energy lost bringing the motor and load up to operating speed.

As can be seen, direct start-up has the following disadvantages:

- the difference between start-up torque (C_a) and the load requirement (C_m) is very low; the maximum torque is between 80%-85% of the operating speed.
- the current absorbed during start-up may be up to 6 times the rated current, causing electrical overloads and higher costs, an increase in motor temperature and fewer possible start-ups.

To limit peak currents, a characteristic of direct start-ups, a system with reduced voltage for start-ups must be used, most commonly the Y / Δ system. In this way the current and peak torque are reduced by about 1/3 compared to direct starting.

The disadvantages of this type of start-up include:

- greater costs for wiring (2 3-pole cables per motor)
- high currents when switching from Y to Δ
- you cannot choose start-up features because current/torque parameters are pre-set and cannot be adjusted.
- It cannot be used for applications where the start-up requires a high load or resistant torque.

START-UP WITH ROTOFUID FLUID COUPLING

With a ROTOFUID fluid coupling between the Motor and Driven Equipment or Machine the motor can start up directly and the starting torque (C_a) is used solely to accelerate the rotor and primary part of the connected coupler.

Figure 2. shows the peak current of an electric motor directly connected to the load, with direct start-up, and start-up with a fluid coupling. The dotted line shows the energy lost as heat during start-up without a fluid coupling.

In the first case, the peak current is 6 times the rated current, and continues to be high until the operating speed is reached.

With a ROTOFUID fluid coupling, the peak current is high for only a few seconds (the energy required to accelerate the rotor) and drops to acceptable values throughout the process of reaching operating speed.

CHARACTERISTIC CURVES FOR START-UP WITH FLUID COUPLING

Figure 3. shows a characteristic torque curve for an electric motor, the stall curve of the fluid coupling and the slip curve at operating speed.

The fluid coupling allows the motor to reach 80-85% speed in a few seconds (shift from point A to point B) where it meets the stall curve of the fluid coupling (slip=100%), the point of maximum motor torque.

Point C is the point of functioning of the fluid coupling after the motor has reached operating speed.

The use of a fluid coupling with a delay fill chamber limits maximum torque during start-up, without prejudicing slipping in normal functioning. This allows the motor to quickly increase speed [revs] without hitting the resistant torque (as if it started unloaded). A Fluid coupling with a delay fill feature is fitted with additional chamber in order to reduce the quantity of oil in the working circuit (see Fig. 1). The chamber is in contact with the circuit via calibrated nozzles, which can be set as required (see Fig. 2). The variation in the calibrated nozzle holes changes the time it takes for the oil in the chamber to reach the working circuit, thereby, increasing or decreasing start-up time for the driven machine. When all the oil has flowed from the chamber into the circuit, the fluid coupling reaches the rated speed, transmitting the required torque with minimum slippage (see Fig. 3). Fluid couplings may be fitted with either a single or dual delay fill chamber. With a single delay fill chamber, Ca/Cn torque limitation varies from 180% to 150%, adjusting the quantity of oil. With a dual delay fill chamber Ca/Cn torque limitation varies from 150% to 120%, adjusting the quantity of oil. The advantages of a delay fill chambers are enhanced as the power requirement rises. SCF and DCF delay fill chambers are available from size 30 to size 95P.

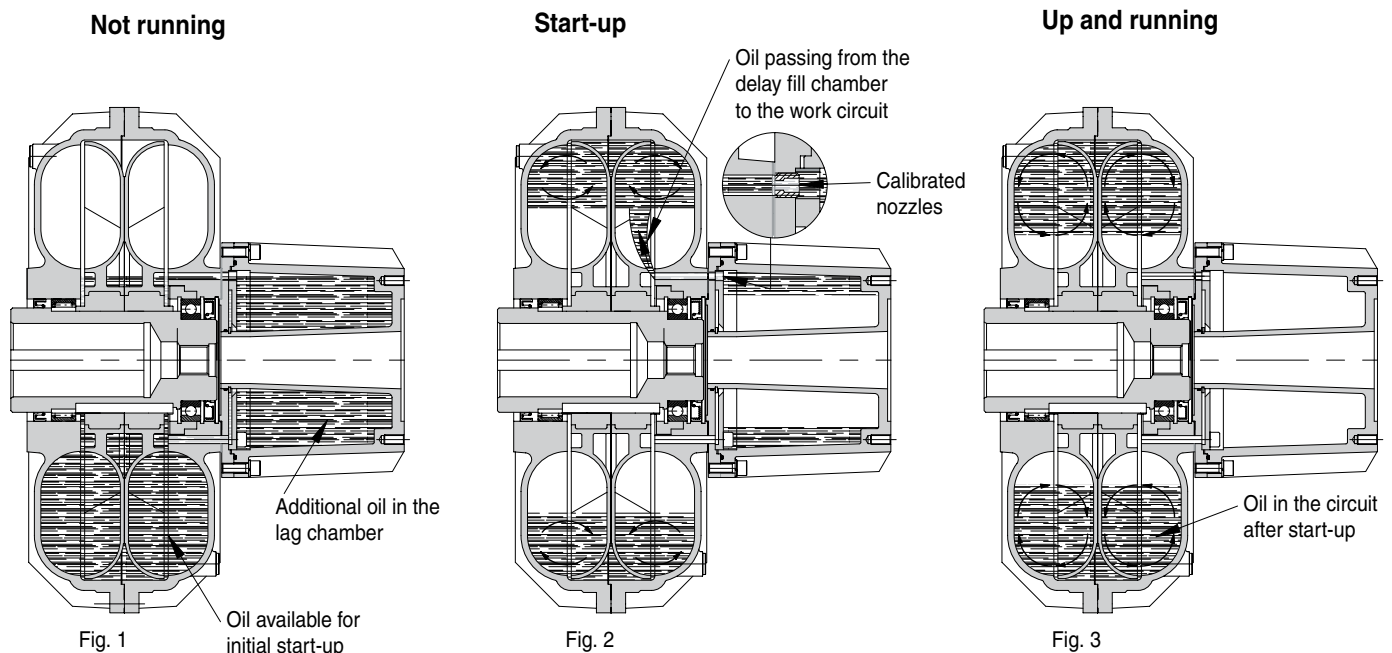

ADVANTAGES

- Low energy loss even where inertia is high
- Start-up time can be adjusted
- Start-up torque is limited to pre-set values without affecting slip
- Limitation of start-up current prolongs the life of the motor
- For controls with several heads the coupling automatically adjusts the load speed on the basis of synchronous speed
- More start-ups per hour
- The direction of rotation can be reversed
- Asynchronous squirrel cage motors can be used instead of electric motors or special starting devices (Inductors, autotransformers, star-delta, etc.)
- If the load is blocked, both the motor and load are protected.

The **ROTOFLUID SCF/DCF** peculiarities are more evident comparing the curve of the ROTOFLUID coupling without delay chamber.

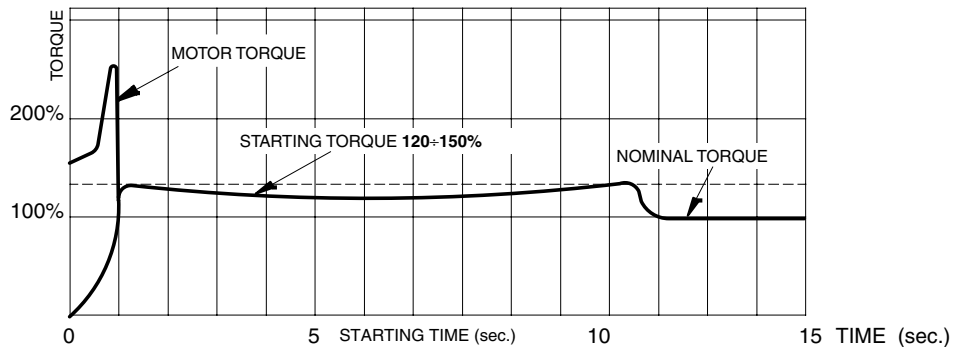
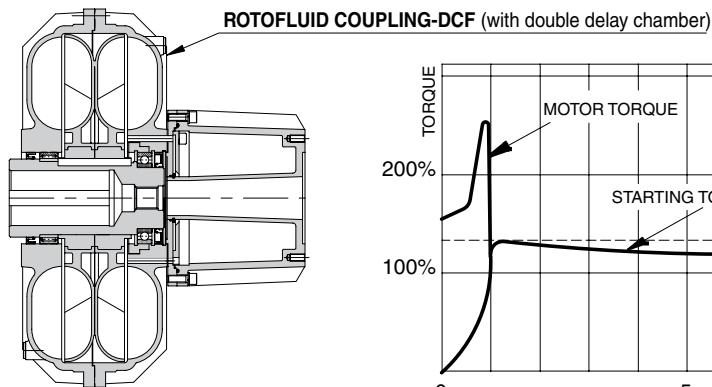
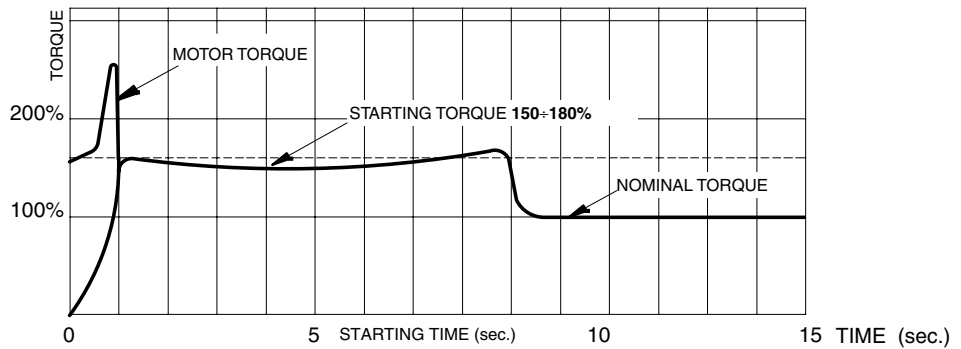
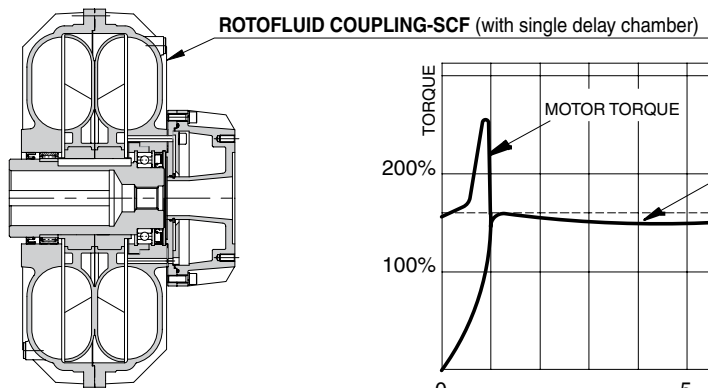
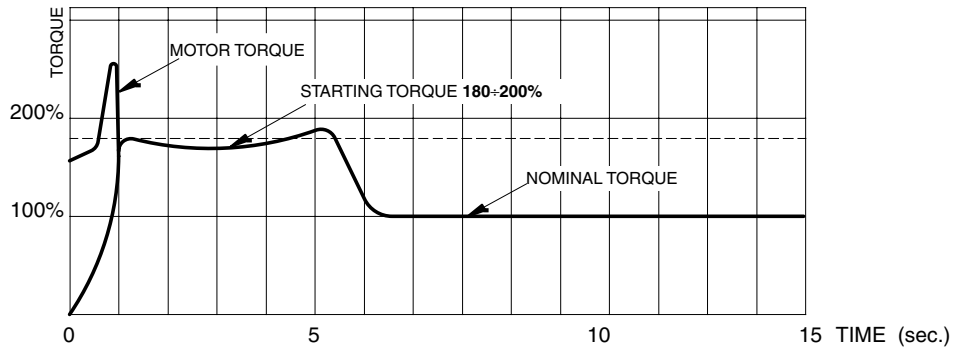
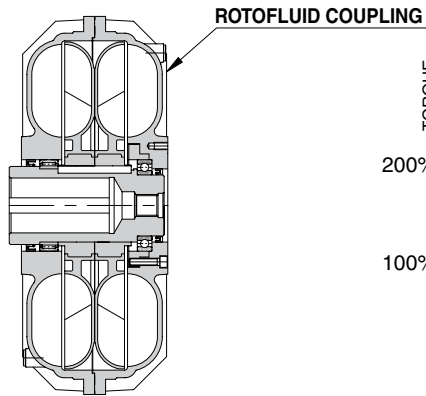

CORRECT MOUNTING OF THE COUPLING WITH DELAY CHAMBER

HORIZONTAL SHAFT

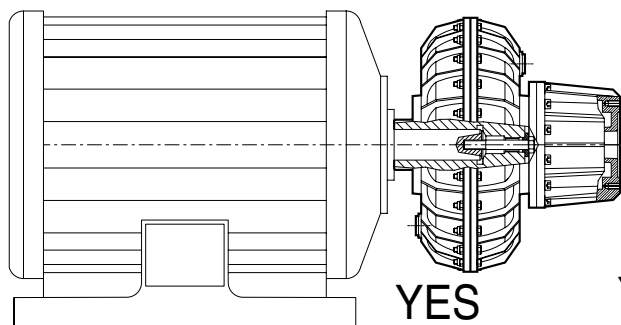

VERTICAL SHAFT WITH
DOWNWARD DELAY CHAMBER

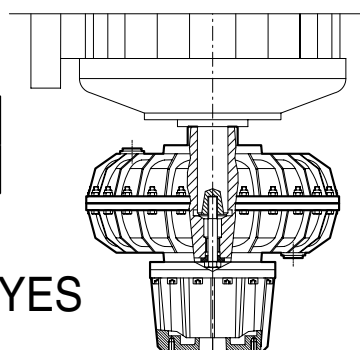

VERTICAL SHAFT WITH UPWARD
DELAY CHAMBER

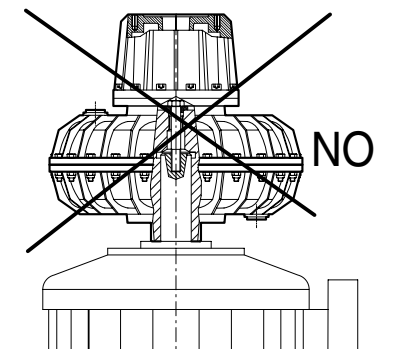

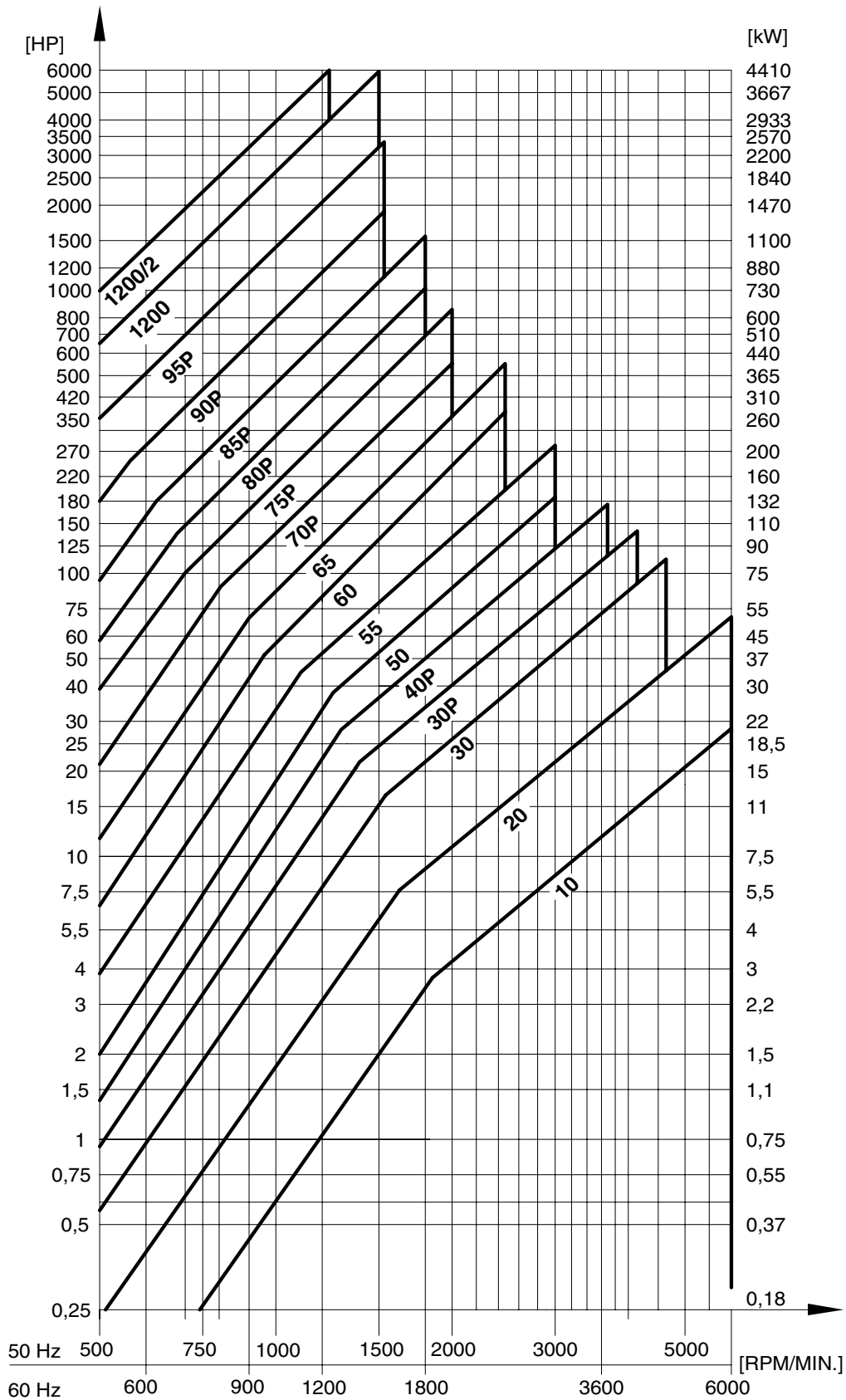

- Select coupling size on input power and speed.
- The curves show limit capacity of couplings.
- If the selection point falls on or close to the max capacity limit line of a given coupling size then it is advisable to check with the starting time and the maximum allowable temperature calculations.

MOTORS		Motor speed 50 Hz												Motor speed 60 Hz									
		8 poles			6 poles			4 poles			2 poles			6 poles			4 poles						
		750 R.P.M.			1000 R.P.M.			1500 R.P.M.			3000 R.P.M.			1200 R.P.M.			1800 R.P.M.						
TYPE	Ø SHAFT	kW	HP	Coupling	kW	HP	Coupling	kW	HP	Coupling	kW	HP	Coupling	kW	HP	Coupling	kW	HP	Coupling				
71	14				0,25	0,33	10	0,25	0,33	10	0,37	0,5	10	0,25	0,33	10	0,25	0,33	10				
80	19				0,37	0,5		0,37	0,5		0,55	0,75		0,75	1		0,37	0,5		0,55	0,75	0,37	0,5
90S	24				0,55	0,75	20	0,75	1	20	1,1	1,5	20	0,75	1	20	0,75	1	20	0,75	1		
90L	24	0,55	0,75	20	1,1	1,5		1,5	2		1,5	2		2,2	3		1,5	2		2,2	3	1,1	1,5
100L	28	1,1	1,5	30	1,5	2	30	2,2	3	30	2,2	3	30	1,5	2	30	2,2	3	30	2,2	3		
112M	28	1,5	2		2,2	3		3	4		4	5,5		4	5,5		4	5,5		4	5,5	2,2	3
132	38	-	-	30P	3	4	30P	5,5	7,5	30	5,5	7,5	30	3	4	30	3	4	30	5,5	7,5		
132M	38	3	4	40P	4	5,5		7,5	10		7,5	10		-	-		7,5	10		5,5	7,5	4	5,5
160M	42	4	5,5	50	7,5	10	40P	11	15	30P	11	15	30P	7,5	10	30P	11	15	30P	11	15		
160L	42	7,5	10	55	11	15		15	20		18,5	25		15	20		18,5	25		11	15	15	20
180M	48	-	-		-	-	50	-	-	40P	-	-	30	-	-	40P	-	-	30P	-	-		
180L	48	11	15		15	20		22	30		22	30		-	-		30	40		37	50	15	20
200L	55	15	20	60	18,5	25	55	22	30	50	30	40	50	18,5	25	50	30	40	40P	30	40		
225S	60	18,5	25		-	-		37	50		-	-		-	-		-	-		-	37	50	-
225M	55	-	-	65	-	-	60	-	-	55	45	60	30P	-	-	55	-	-	50	-	-		
225M	60	22	30		30	40		45	60		-	-		-	-		-	30		40	45	60	-
250M	60	-	-	65	-	-	65	-	-	55	55	75	40P	-	-	60	-	-	65	-	-		
250M	65	30	40		37	50		55	75		-	-		-	-		-	37		50	55	75	-
280S	65	-	-	70P	-	-	70P	-	-	60	75	100	50	-	-	60	-	-	65	-	-		
280S	75	37	50		45	60		75	100		-	-		-	-		-	45		60	75	100	-
280M	65	-	-	70P	-	-	70P	-	-	60	90	125	50	-	-	65	-	-	65	-	-		
280M	75	45	60		55	75		90	125		-	-		-	-		-	55		75	90	125	-
315S	65	-	-	75P	-	-	70P	-	-	65	110	150	55	-	-	65	-	-	65	-	-		
315S	80	55	75		75	100		110	150		-	-		-	-		-	75		100	110	150	-
315M	65	-	-	75P	-	-	75P	-	-	70P	132	180	55	-	-	75P	-	-	75P	-	-		
		75	100		90	125		132	180		-	-		90	125		132	180		90	125	132	180
		90	125		110	150		160	220		-	-		110	150		160	220		110	150	160	220
355S	80	-	-	80P	-	-	80P	-	-	75P	200	270	55	-	-	75P	-	-	75P	-	-		
		100	132		180	85P		160	220		250	340		-	-		160	220		250	340	160	220
355M	80	-	-	85P	-	-	85P	-	-	75P	-	-	55	-	-	75P	-	-	75P	-	-		
		100	160		220	85P		200	270		315	430		-	-		200	270		315	430	200	270
NON STANDARD MOTORS		330	450	90P	370	500	85P	510	700	80P				310	420	80P	440	600	75P				
		600	800	95P	600	800	90P	810	1100	85P				440	600	85P	700	950	80P				
		1000	1360	1200	1000	1360	95P	1300	1740	90P				800	1100	90P	1000	1360	85P				
		1550	2100	1200/2	2000	2720	1200	2300	3100	95P				1380	1880	95P							
					3200	4350	1200/2	3850	5250	1200				2580	3500	1200							
														4200	5710	1200/2							

- For Couplings at 3000 RPM, ask for special execution
- Slip curves with Couplings efficiency are available on request

The preliminary selection of ROTOFLUID coupling, will be made on the selection diagram sheet 10 - 100A depending upon input power and speed. For frequent starts or high inertia acceleration, it is necessary first to carry out the following calculations:

- 1 Acceleration time (ta)
- 2 Max allowable temperature (Ta)
- 3 Max working cycles for hours (H)

For this purpose it is necessary to know:

DATA

Pm = INPUT POWER KW
Nm = INPUT SPEED RPM
(*) Nu = COUPLING OUTPUT SPEED RPM
PI = POWER ABSORBED BY THE LOAD AT RATED SPEED KW
NI = SPEED OF DRIVEN MACHINE RPM
T = AMBIENT TEMPERATURE °C

$J = \text{INERTIA OF DRIVEN MACHINE} \quad \frac{1}{4} \left(\frac{PD^2}{\dots} \right) \text{ kgm}^2$

$J_r = \text{INERTIA OF DRIVEN MACHINE REFERED TO COUPLING SHAFT (kgm}^2) \quad J_r = J \left(\frac{NI}{Nu} \right)^2$

(*) $Nu = \left(\frac{100 - S}{100} \right)$ WHERE: S = Percent slip of the ROTOFLUID coupling

The following assumptions may be made for initial calculations: S = 4

1 ACCELERATION TIME

For the calculation of the acceleration time apply the following formula:
The outcome time is worded in seconds

$$ta = \frac{Nu \times Jr}{9,55 \times Ma} = \dots\dots\dots (\text{sec})$$

WHERE:

Ma = ACCELERATING TORQUE (Nm)

$$Ma = 1,65 \times Mm - MI = \dots\dots\dots (\text{Nm})$$

Mm = NOMINAL TORQUE (Nm)

$$Mm = \frac{9550 \times Pm}{Nm} = \dots\dots\dots (\text{Nm})$$

MI = ABSORBED TORQUE (Nm)

$$MI = \frac{9550 \times PI}{Nu} = \dots\dots\dots (\text{Nm})$$

2 MAX ALLOWABLE TEMPERATURE

For simplicity of calculation, ignore the heat dissipated during acceleration. Coupling temperature rise:

$$Ta = \frac{Q}{C} = \dots\dots\dots (^\circ\text{C})$$

WHERE:

Q = HEAT GENERATED DURING ACCELERATION (Kcal)

C = TOTAL THERMAL CAPACITY OF COUPLING SELECTED FROM TABLE BESIDE

$$Q = \frac{Nu}{10^4} \left(\frac{Jr \times Nu}{76,5} + \frac{MI \times ta}{8} \right) = \dots\dots\dots (\text{Kcal})$$

The final coupling temperature reached at the end of the acceleration cycle will be:

$$Tf = T + Ta + TL (^\circ\text{C})$$

where: Tf = Final temperature (°C)

T = Ambient temperature (°C)

Ta = Temperature rise during acceleration (°C)

TL = Temperature increase during steady running (°C)

$$TL = 2,4 \frac{PI \times S}{K} (^\circ\text{C})$$

where: K = factor from TAB. D

THERMAL CAPACITY OF ROTOFLUID COUPLINGS			TABLE C
Size	Without SCF/DCF Kcal / °C	With SCF Kcal / °C	With DCF Kcal / °C
10	0,73	-	-
20	1,2	-	-
30	2,8	3,1	3,3
30P	3,5	3,8	4
40P	4	4,7	5
50	6,1	6,9	7,4
55	8,8	9,6	10,1
60	13	14,8	16
65	15,2	17	18,2
70P	22	25,6	27,8
75P	28,6	32,2	34,4
80P	44	50	55
85P	55	61	66
90P	98	100	104
95P	133	138	142
1200	180	-	-
1200/2	250	-	-

3 MAX WORKING CYCLES FOR HOUR H

In addition to the heat generated in the coupling by slip during steady running, heat is also generated (as calculated above) during the acceleration period. To allow time for this heat to be dissipated, one must not exceed the max allowable number of acceleration cycles for hour. This is calculated as follows:

$$H_{max} = \frac{3600}{t_a + t_L}$$

where t_L = minimum working time

$$t_L = 10^3 \frac{Q}{T_a \times K} \text{ (sec)}$$

WARNING:

**ROTOFLUID couplings equipped with standard (NBR) oil seals must not exceed the maximum value T120°C.
In the version with Viton seals the maximum value Tf = 180°C.**

In case the above performance calculations result shows unsuitable values, check again with a larger ROTOFLUID size or consult with Westcar technical office.

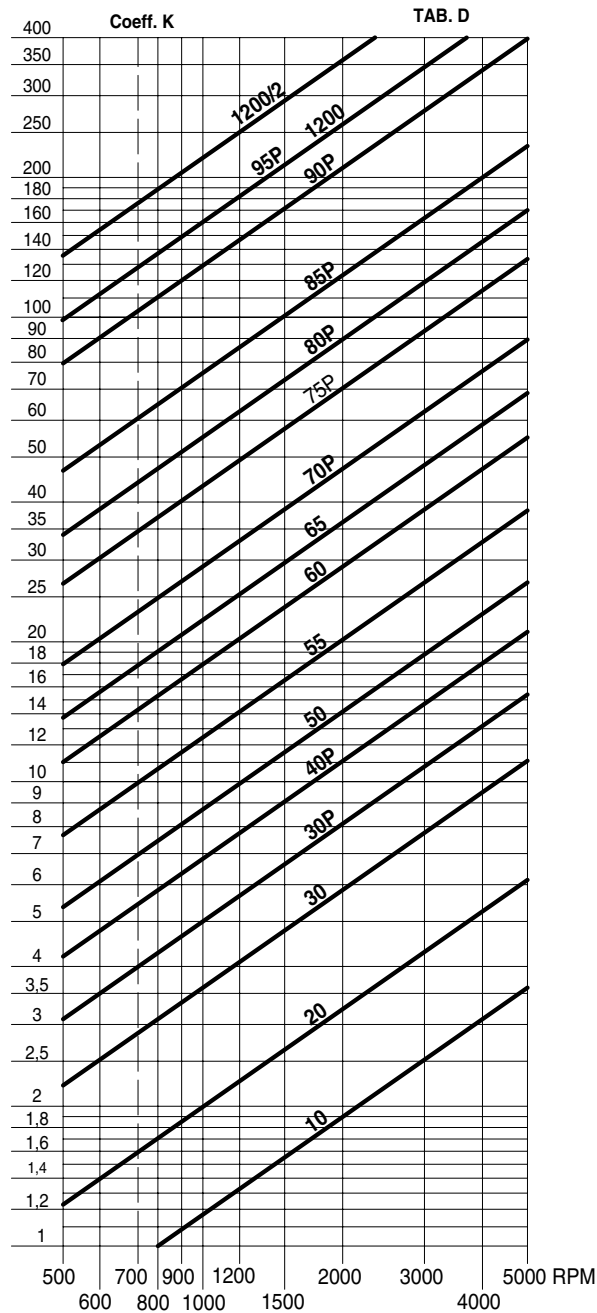

The mass moment of inertia values listed in the table below are referred to inner part, outer part and oil where:

INNER PART = hollow shaft, impeller pump, half oil

OUTER PART = turbine and cover housing, half oil

values valid for ROTOFLUID couplings with oil level at 45° off center pulleys, flexible couplings and other accessories are not included.

INNER PART	OUTER PART	INNER PART	OUTER PART	DELAY CHAMBER
SIZE: 10, 20, 30, 30P, 40P, 50, 60, 70P, 80P, 90P.		SIZE: 55, 65, 75P, 85P, 95P.		

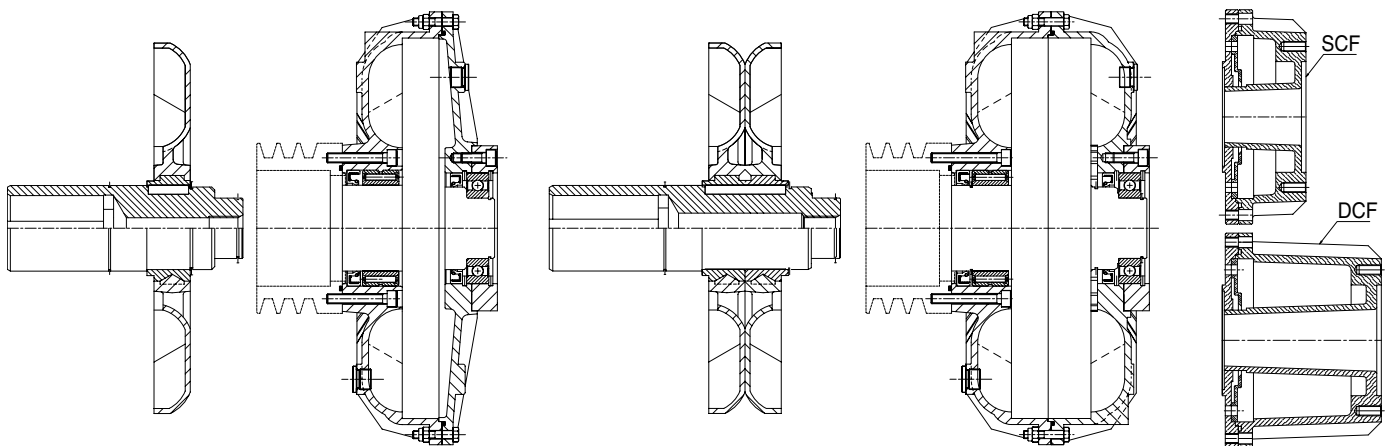

$$\text{MOMENT OF INERTIA } I = \frac{m \times R^2}{2} \text{ (Kgm}^2\text{)}$$

ROTOFLUID COUPLING SIZE	VERSION ALFA		VERSION BETA						DELAY CHAMBER	
	Type K		Type Z, X, I		Type J		Type H		SCF	DCF
	I INNER Kgm ²	I OUTER Kgm ²	I INNER Kgm ²	I OUTER Kgm ²	I INNER Kgm ²	I OUTER Kgm ²	I INNER Kgm ²	I OUTER Kgm ²	I Kgm ²	I Kgm ²
10	0,003	0,011	0,003	0,011	--	--	0,003	0,012	--	--
20	0,006	0,024	0,006	0,024	0,006	0,026	0,006	0,027	--	--
30	0,021	0,081	0,022	0,081	0,022	0,084	0,022	0,086	0,006	0,007
30P	0,040	0,140	0,045	0,140	0,045	0,144	0,045	0,147	0,006	0,007
40P	0,060	0,179	0,065	0,179	0,065	0,190	0,065	0,197	0,013	0,016
50	0,105	0,363	0,109	0,363	0,109	0,376	0,109	0,385	0,026	0,032
55	0,208	0,474	0,214	0,474	0,214	0,487	0,214	0,496	0,026	0,032
60	0,311	0,795	0,326	0,795	0,326	0,823	0,326	0,842	0,053	0,062
65	0,564	1,040	0,583	1,040	0,583	1,068	0,583	1,087	0,053	0,062
70P	0,710	2,230	0,780	2,230	0,780	2,307	0,780	2,357	0,11	0,140
75P	1,426	2,834	1,462	2,834	1,462	2,911	1,462	2,961	0,11	0,140
80P	2,389	7,276	2,499	7,276	2,499	7,393	--	--	0,215	0,254
85P	4,668	8,977	4,792	8,977	4,792	9,094	--	--	0,215	0,254
90P	8,372	23,200	--	--	--	--	--	--	0,490	0,550
95P	15,613	28,855	--	--	--	--	--	--	0,490	0,550
1200	54,000	260,000	--	--	--	--	--	--	--	--
1200/2	104,000	320,000	--	--	--	--	--	--	--	--

**ALL THE ACCESSORIES CAN BE FITTED TO THE COUPLINGS ALFA WITH DELAY
FILL CHAMBERS "SCF AND DCF"**

**ROTOFLUID ALFA without accessories
K**

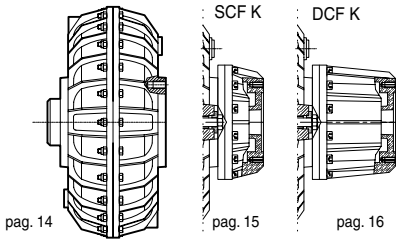

**ROTOFLUID ALFA KK reverse assembly
with disc or brake drum**

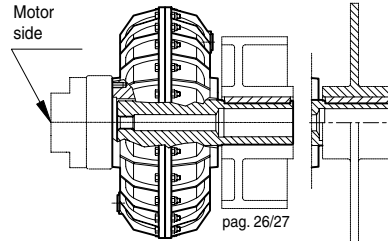

ROTOFLUID ALFA KS with rigid stub shaft

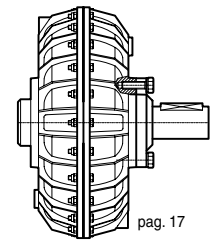

**ROTOFLUID ALFA K-LRV/LRU
with standard ROTOFLEXI
flexible coupling**

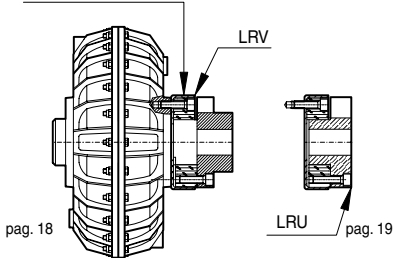

**ROTOFLUID ALFA K-FRV/FRU with
ROTOFLEXI oversized flexible coupling**

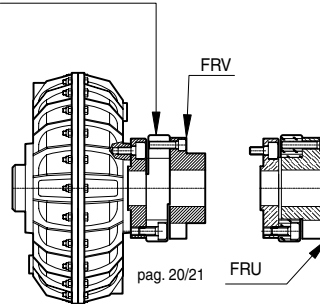

**ROTOFLUID ALFA K-AB with
ROTOPIN flexible coupling**

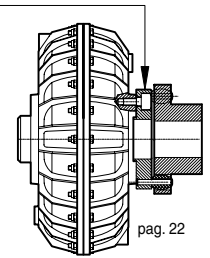

**ROTOFLUID ALFA K-FRD with ROTOFLEXI
oversized flexible coupling and brake drum**

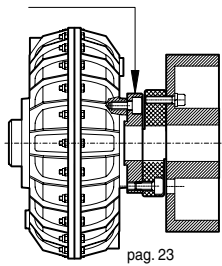

**ROTOFLUID ALFA K-AFF with ROTOPIN
flexible coupling and brake drum**

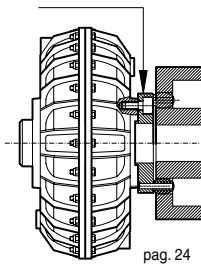

**ROTOFLUID ALFA K-FR-PAV/PBV
with flexible coupling and brake disc**

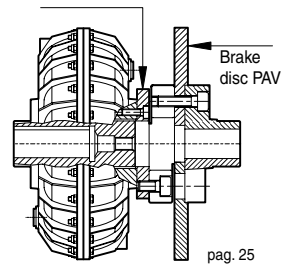

**ROTOFLUID ALFA WAG
with flanges for the mounting of half
gear couplings in inches**

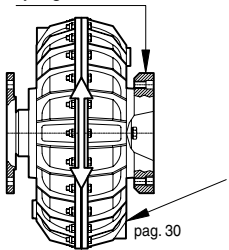

Fluid couplings radially
demountable without
moving the machines

**ROTOFLUID ALFA WAG-G with
ROTOGEAR coupling**

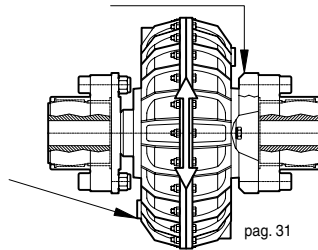

ROTOFLUID ALFA CK-LRS

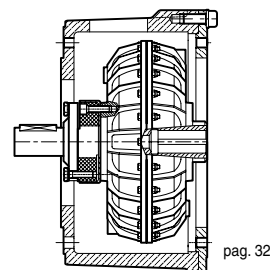

SPECIAL CONFIGURATIONS EXAMPLES FOR COUPLING ROTOFLUID ALFA

**ROTOFLUID ALFA K-W
with flange shaft**

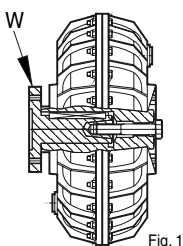

**ROTOFLUID ALFA K-Y
with pin shaft**

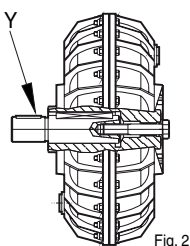

**ROTOFLUID ALFA K-VFW
with rigid hub**

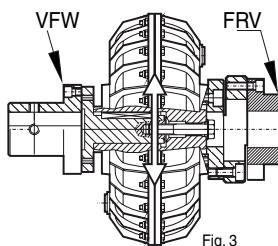

**ROTOFLUID ALFA K-VF
for "reverse mounting"**

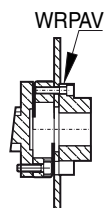
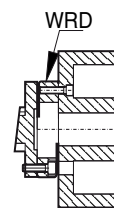
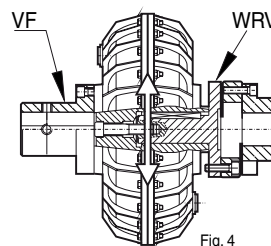

STANDARD ASSEMBLY

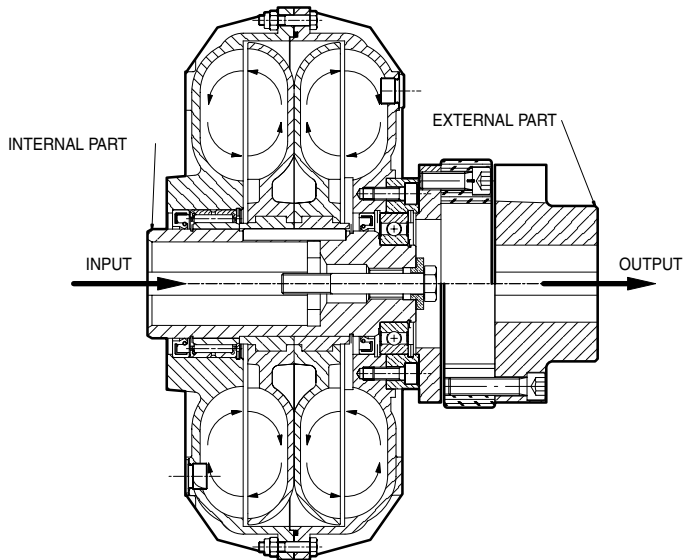

REVERSE ASSEMBLY

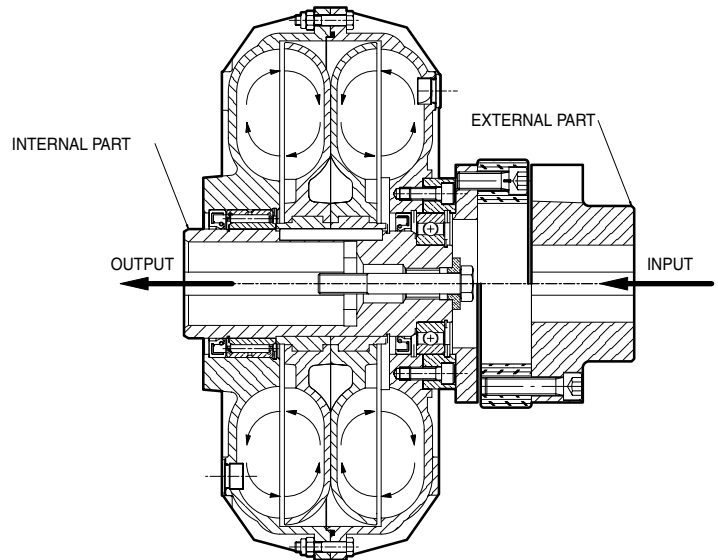

ADVANTAGES OF STANDARD ASSEMBLY

In STANDARD assemblies, the fluid coupling is fitted with the internal part keyed to the motor.

This is common for couplings with pulleys and linear couplings, and provides the following benefits:

- A) – Standardisation of bores in compliance with unified electric motor shafts;
- B) – During start-up the inertia of the coupling affects the motor less, so the motor can reach operating speed with less peak current;
- C) – In linear applications, where a brake disc/drum are required, they are keyed directly onto the reduction gear shaft without increasing the axial length of the coupling.
- D) – In couplings with delay fill chambers, start-up is more gradual because the oil passing from the delay fill chamber is subjected to centrifugal forces in the work chamber as revs rise;
- E) – The flexible coupling fitted to the fluid coupling is subject to less stress, because it receives motion from the fluid coupling not directly from the motor.

ADVANTAGES OF REVERSE ASSEMBLY

In a REVERSE assembly, the fluid coupling is fitted with the external part keyed to the motor.

This type of assembly is possible whenever the fluid coupling is fitted between the motor and the reduction gear.

For couplings with a Vee Pulley, the coupling must be fitted to the driving shaft and attention needs to be paid to the ratio between the Driving pulley and Driven pulley. **(In this case consult WESTCAR S.R.L.)**

This type of assembly has the following important benefits:

- F) - Greater dissipation of heat, above all during start-up, recommended where start-ups are frequent or lengthy;
- G) - Control is easier and the regulation of the oil level in the coupling is simplified, since the external part can be rotated without moving the Driven Equipment or Machine;
- H) - **IMPORTANT!** Where the coupling is fitted with THERMAL TRIP PIN, it continues to function even when the Driven Equipment or Machine comes to rest and the motor is rotating.

In the absence of special needs or requests, the coupling is supplied for the Standard configuration.

Please advise **WESTCAR S.R.L.** if you require, the selected Fluid Coupling to be quoted for Reverse Assembly.

ROTOFLEXI flexible coupling

ROTOPIN flexible coupling

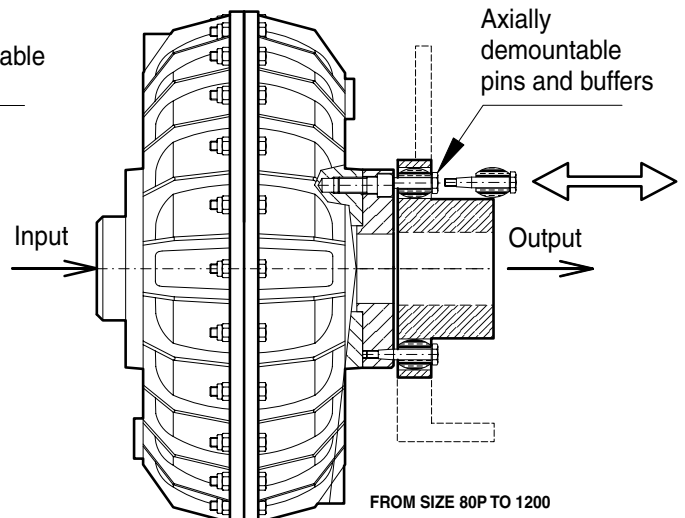
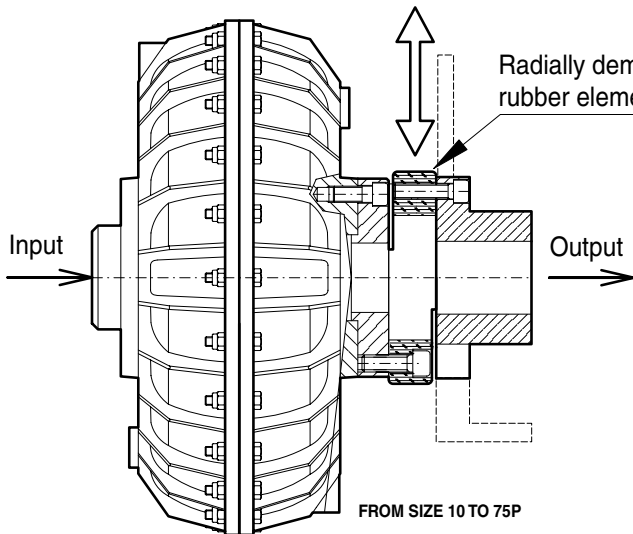

Rubber elements type « R » available also with reinforced fabric and higher safety factor, type « BR ».

COUPLING	750 R.P.M.		COUPLING	1000 R.P.M.		COUPLING	1500 R.P.M.		COUPLING	3000 R.P.M.				
	HP	KW		HP	KW		HP	KW		CV/HP	KW			
20 K-LR...-2	0,75	0,55	10 K-LR...-1	0,33	0,25	10 K-LR...-1	0,33	0,25	10 K-LR...-1	1	0,75			
30 K-LR...-3	1,5	1,1	20 K-LR...-2	0,5	0,37		0,5	0,37		1,5	1,1			
30P K-LR...-3	2	1,5	20 K-LR...-2	0,75	0,55	0,75	0,55	2		1,5				
40P K-LR...-4	4	3	20 K-LR...-2	1	0,75	1	0,75	3		2,2				
50 K-LR...-5	5,5	4	20 K-LR...-2	1,5	1,1	1,5	1,1	4		3				
55 K-LR...-5	10	7,5	30 K-LR...-3	2	1,5	2	1,5	5,5	4					
60 K-LR...-6	15	11	30 K-LR...-3	3	2,2	20 K-LR...-2	3	2,2	20 K-LR...-2	7,5	5,5			
	20	15	30P K-LR...-3	4	3		4	3		10	7,5			
65 K-LR...-6	25	18,5	30P K-LR...-3	5,5	4	30 K-LR...-3	5,5	4	30 K-LR...-3	15	11			
	30	22	40P K-LR...-4	7,5	5,5		7,5	5,5		20	15			
65 K-FR...-7	40	30	40P K-LR...-4	10	7,5	30P K-FR...-4	10	7,5	30 K-FR...-4	25	18,5			
70P K-LR...-7	50	37	50 K-LR...-5	15	11		15	11		30	22			
	75P K-FR...-8	75	55	50 K-LR...-5	20	15	40P K-FR...-5	20	15	30P K-FR...-4	40	30		
100		75	55 K-LR...-5	25	18,5	25		18,5	50		37			
80P K-AB-8	125	90	60 K-LR...-6	30	22	50 K-FR...-6	30	22	40P K-FR...-5	60	45			
80P K-AB-8	150	110	60 K-LR...-6	40	30		40	30		75	55			
85P AB-8M	180	132	65 K-FR...-7	50	37	55 K-FR...-6	50	37	50 K-FR...-6	100	75			
	85P K-AB-8M	220	160	65 K-FR...-7	60		45	60		45	125	90		
90P K-AB-9		270	200	70P K-LR...-7	75	55	60 K-FR...-7	75	55	50 K-FR...-6x2	150	110		
	90P K-AB-9	450	330 ★	70P K-FR...-8	100	75		100	75		180	132		
95P K-AB-9		800	600 ★	75P K-FR...-8	125	90	70P K-FR...-8	125	90	50 K-FR...-6x2	220	160		
	1200 K-AB-9	1600	1200 ★	75P KFR...-8x2	150	110		150	110		270	200		
For higher power contact WESTCAR Technical Dept.				80P K-AB-8	180	132	75P K-FR...-8	180	132	For higher power contact WESTCAR Technical Dept.				
	80P K-AB-8			220	160	220		160						
	85P K-AB-8M			270	200	80P K-AB-8	270	200	80P K-AB-8				270	200
	85P K-AB-8M			340	250	85P K-AB-8M	340	250					340	250
	85P K-AB-8M			500	370	85P K-AB-8M	500	370	500				370	
	90P K-AB-9			800	600 ★	90P K-AB-9	800	600 ★	80P K-AB-8				500	365 ★
	95P K-AB-9			1360	1000 ★	95P K-AB-9	1360	1000 ★	85P K-AB-8M				600	450 ★
	1200 K-AB-9 (1)			2720	2000 ★	1200 K-AB-9 (1)	2720	2000 ★	90P K-AB-9				700	525 ★
									90P K-AB-9				1100	810 ★
									95P K-AB-9				1740	1300 ★
						95P K-AB-9	3100	2300 ★						

★ Maximum power transmitted by the fluid coupling for no standard motors.

(1) Check flexible coupling duty factor with the rated motor power

NOTE - For REVERSE MOUNTING advise WESTCAR

NOTE - For couplings running at 3000 R.P.M. contact WESTCAR Technical Dept.

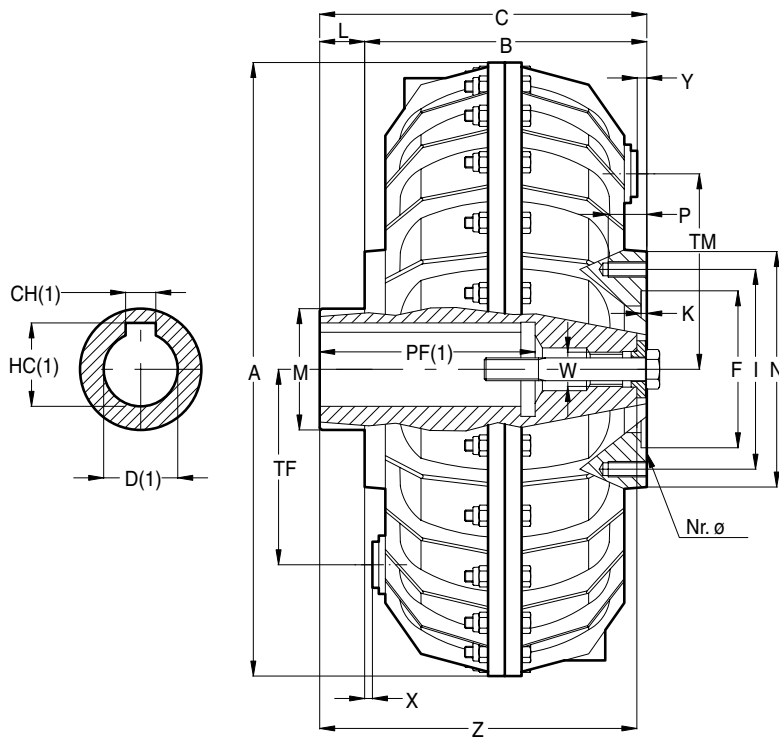

NOTE: (1) FOR BORE AND KEYWAY DIMENSIONS SEE SHEET 10-019D

Size	Type	Dimensions in mm																	Weight	
		D	A	B	C	F ^{H7}	K	I	L	M	N	Nr.Ø	P	TF	TM	W	X	Y	Z	Kg.*
10	K-1	14-19-24 28	193	88	98	47	4	60	10	35	75	6-M6	12	66	66	ø8,5	0,5	0	94	4
	K-3				114	2	26	40	9	0,5	112									
20	K-1	19-24-28 38	230	115	125	62	4	78	10	40	94	6-M8	16	80	80	M14 M16	2	7	120	6
	K-3				135	52	20	53	14	2	130									
30	K-1	28-38-42 48 ** 55	290	150	162	75	4	100	12	55	114	8-M8	16	110	110	M24	9	9	157,5	13,2
	K-3				190	72	40	60	185,5											
	K-4				219	72	69	70	214,5											
30P	K-1	28-38-42 48 ** 55	327	150	162	75	4	100	12	55	114	8-M8	16	130	130	M24	4	4	157,5	21
	K-3				190	72	40	60	185,5											
	K-4				219	72	69	70	214,5											
40P	K-1	38-42-48-55 60	338	183	198	100	4	125	15	70	145	8-M10	22	130	130	M24	11	24	194	22
	K-2				90	80	24	11	193											
50	K-2	42-48-55-60-65	430	154	179	110	4,5	140	25	85	165	8-M10	22	150	150	M24	6	20	176,5	30
55	K-2	42-48-55-60-65 75	430	196	211	110	4,5	140	15	85	165	8-M10	22	150	150	M24 M30	6	6	208,5	40
	K-3				210	100	6	207,5												
60	K-2	48-55-60-65-75 80	520	172	192	125	8	160	20	110	185	8-M10	22	205	192	M30	6	20	192	46
	K-3				222	50	222													
65	K-2	55-60-65-75-80	520	220	240	125	8	160	20	110	185	8-M10	22	205	205	M30	6	6	240	66
70P	K-2N	75-80-90 100	640	190	240	150	4	195	50	128	225	8-M16	30	265	265	M36	0	15	234	86
	K-3N				280	90	15	274												
75P	K-2N	80-90 100	640	245	265	150	4	195	20	128	225	8-M16	30	265	265	M36	0	0	254	127
	K-3N				280	35	0	269												
80P	K-2N	max. 110 max. 125***	810	226	270	160	5	230	44	160	270	8-M18	28	325	325	M36	0	15	264	180
	K-3N				286	60	0	280												
85P	K-2N	max. 125 max. 135	810	300	340	160	5	230	40	160	270	8-M18	28	325	325	M36	0	0	334	252
	K-3N				464	170	0	334												
90P	K-2	max. 130 max. 140***	1000	344	364	445	5	506	20	170	550	16-M20	32	416	416	M36	0	35	343	350
	K-3				464	120	0	390												
95P	K-2	max. 130 max. 140***	1000	466	479	445	5	506	13	170	550	16-M20	32	416	416	M36	0	35	420	505
	K-3				586	120	0	555												
1200	K-2	max. 190	1300	425	462	220	7	310	7	240	570	16-M20	36	430	430	M36	0	30	419	1800

* Weight with oil - ** Reduced keyway - *** Depth of bore PF = 210 (for larger bores consult WESTCAR) - Standard bores in heavy type

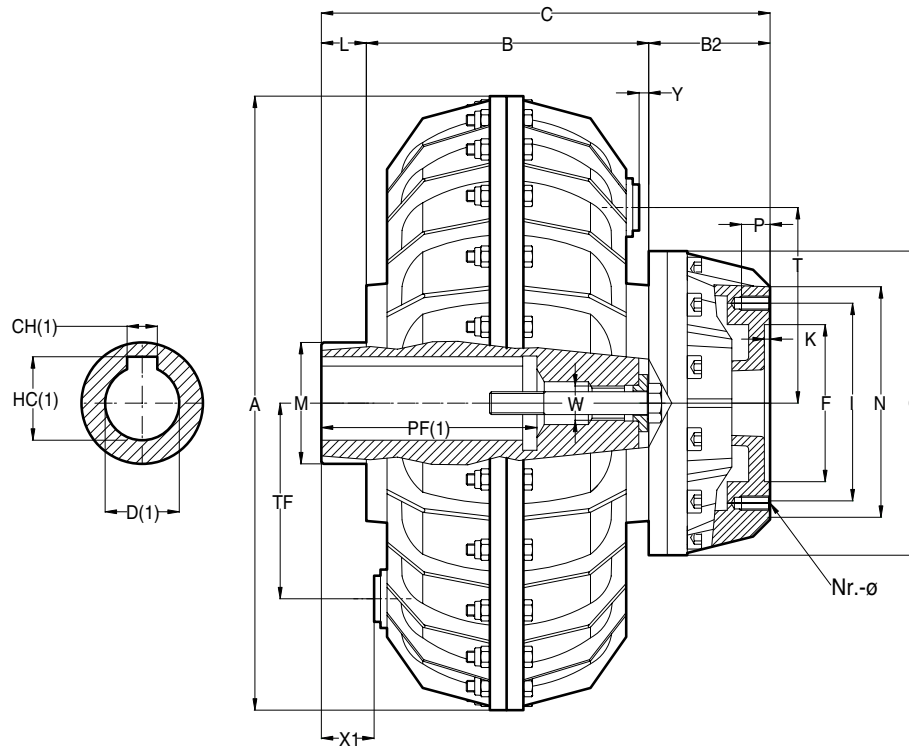

NOTE: (1) FOR BORE AND KEYWAY DIMENSIONS SEE SHEET 10-019D

Size	Type	D	Dimensions mm																	Weight Kg.*	
			A	B	C	B2	F ^{H7}	K	I	L	M	N	Nr.Ø	O	P	TF	TM	W	X1		Y
30 SCF	K-2	28-38-42			217		75		12	55								21		15,6	
	K-3	48 **	290	150	245	55	72	4	100	40	60	114	8-M8	156	16	110	110	M24	49	9	15,6
	K-4	55			274		72			69	70							78		16,4	
30P SCF	K-2	28-38-42			217		75		12	55								16		23,4	
	K-3	48 **	327	150	245	55	72	4	100	40	60	114	8-M8	156	16	110	110	M24	44	4	23,4
	K-4	55			274		72			69	70							73		24,4	
40P SCF	K-2	38-42-48-55-60	338	183	256	58	90	4	125	15	80	145	8-M10	185	20	130	130	M24	39	11	25,7
50 SCF	K-2	42-48-55-60-65	430	154	259	80	110	4,5	140	25	85	165	8-M10	213	22	150	150	M24	31	20	35,8
55 SCF	K-2	42-48-55-60-65	430	196	291	80	110	4,5	140	15	85	165	8-M10	213	22	150	150	M24	21	6	45,8
	K-3	75			290					14	100										
60 SCF	K-2	48-55-60-65-75	520	172	282	90	125	8	160	20	110	185	8-M10	245	22	205	192	M30	26	20	54,4
	K-3	80			312					50											
65 SCF	K-2	55-60-65-75-80	520	220	330	90	125	8	160	20	110	185	8-M10	245	22	205	205	M30	26	6	74,4
70P SCF	K-2N	75-80-90	640	190	350	110	150	4	195	50	128	225	8-M16	288	30	265	265	M36	50	15	99
	K-3N	100			390					90											
75P SCF	K-2N	80-90	640	245	375	110	150	4	195	20	128	225	8-M16	288	30	265	265	M36	20	0	140
	K-3N	100			390					35											
80P SCF	K-2N	max. 110	810	226	388	118	160	5	230	44	160	270	8-M18	375	28	325	325	M36	44	15	196
	K-3N	max. 125***			404					60											
85P SCF	K-2N	max. 125	810	300	458	118	160	5	230	40	160	270	8-M18	375	28	325	325	M36	40	0	268
	K-3N	max. 135			170																
90P SCF	K-2	max. 130	1000	344	424	120	445	5	506	20	170	550	16-M20	630	32	416	416	M36	20	35	390
	K-3	max. 140***			524					120											
95P SCF	K-2	max. 130	1000	466	599	120	445	5	506	13	170	550	16-M20	630	32	416	416	M36	13	35	545
	K-3	max. 140***			706					120											

* Weight with oil - ** Reduced keyway - *** Depth of bore PF = 210 (for larger bores consult WESTCAR) - Standard bores in heavy type

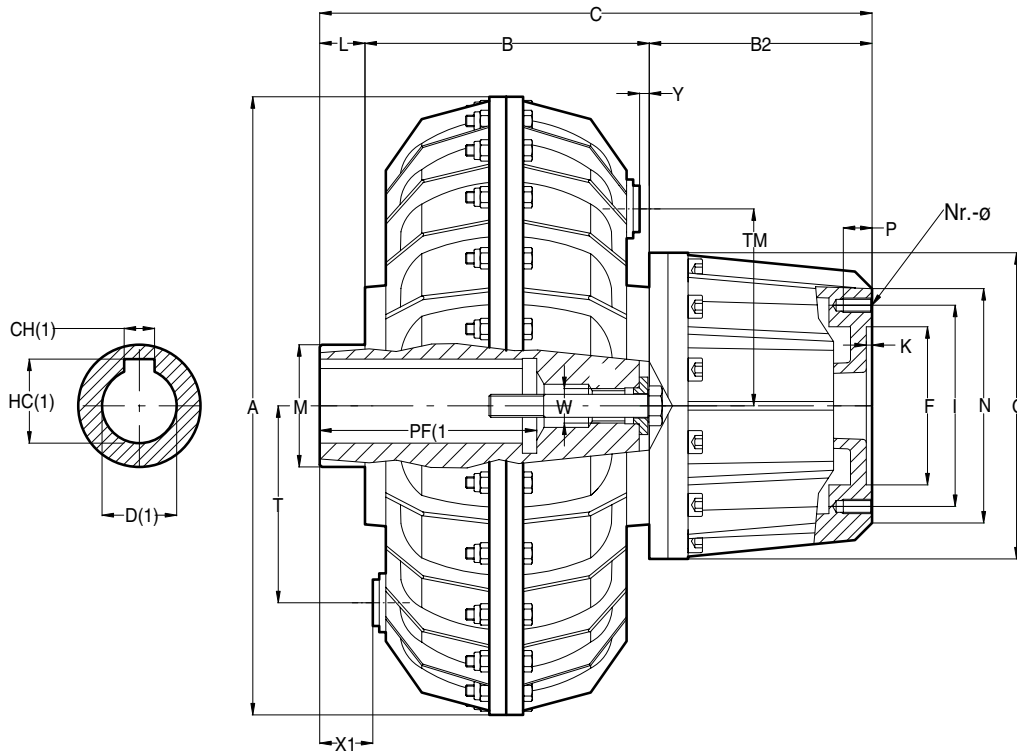

NOTE: (1) FOR BORE AND KEYWAY DIMENSIONS SEE SHEET 10-019D

Size	Dimensions mm																			Weight Kg. *	
	Type	D	A	B	C	B2	F ^{H7}	K	I	L	M	N	Nr.Ø	O	P	TF	TM	W	X1		Y
30 DCF	K-2	28-38-42	290	150	257	95	75	4	100	12	55	114	8-M8	156	16	110	110	M24	21	9	16,2
	K-3	48 **			285		72			40	60								78		
	K-4	55			314		72			69	70								17,2		
30P DCF	K-2	28-38-42	327	150	257	95	75	4	100	12	55	114	8-M8	156	16	110	110	M24	16	4	24
	K-3	48 **			285		72			40	60								73		
	K-4	55			314		72			69	70								25		
40P DCF	K-2	38-42-48-55-60	338	183	328	130	90	4	125	15	80	145	8-M10	185	20	130	130	M24	39	11	27,2
50 DCF	K-2	42-48-55-60-65	430	154	334	155	110	4,5	140	25	85	165	8-M10	213	22	150	150	M24	31	20	38
55 DCF	K-2	42-48-55-60-65	430	196	366	155	110	4,5	140	15	85	165	8-M10	213	22	150	150	M24	21	6	48
	K-3	75			365					14	100								20		
60 DCF	K-2	48-55-60-65-75	520	172	362	170	125	8	160	20	110	185	8-M10	245	22	205	192	M30	26	20	58
	K-3	80			392					50	56										
65 DCF	K-2	55-60-65-75-80	520	220	410	170	125	8	160	20	110	185	8-M10	245	22	205	205	M30	26	6	78
70P DCF	K-2N	75-80-90	640	190	465	225	150	4	195	50	128	225	8-M16	288	30	265	265	M36	50	15	106
	K-3N	100			505					90	90										
75P DCF	K-2N	80-90	640	245	490	225	150	4	195	20	128	225	8-M16	288	30	265	265	M36	20	0	147
	K-3N	100			505					35	35										
80P DCF	K-2N	max. 110	810	226	488	218	160	5	230	44	160	270	8-M18	375	28	325	325	M36	44	15	208
	K-3N	max. 125***			504					60	60										
85P DCF	K-2N	max. 125	810	300	558	218	160	5	230	40	160	270	8-M18	375	28	325	325	M36	40	0	280
	K-3N	max. 135			170					170											
90P DCF	K-2	max. 130	1000	344	504	200	445	5	506	20	170	550	16-M20	630	32	416	416	M36	20	35	405
	K-3	max. 140***			604					120	120										
95P DCF	K-2	max. 130	1000	466	679	200	445	5	506	13	170	550	16-M20	630	32	416	416	M36	13	35	560
	K-3	max. 140***			786					120	120										

* Weight with oil - ** Reduced keyway - *** Depth of bore PF = 210 (for larger bores consult WESTCAR) - Standard bores in heavy type

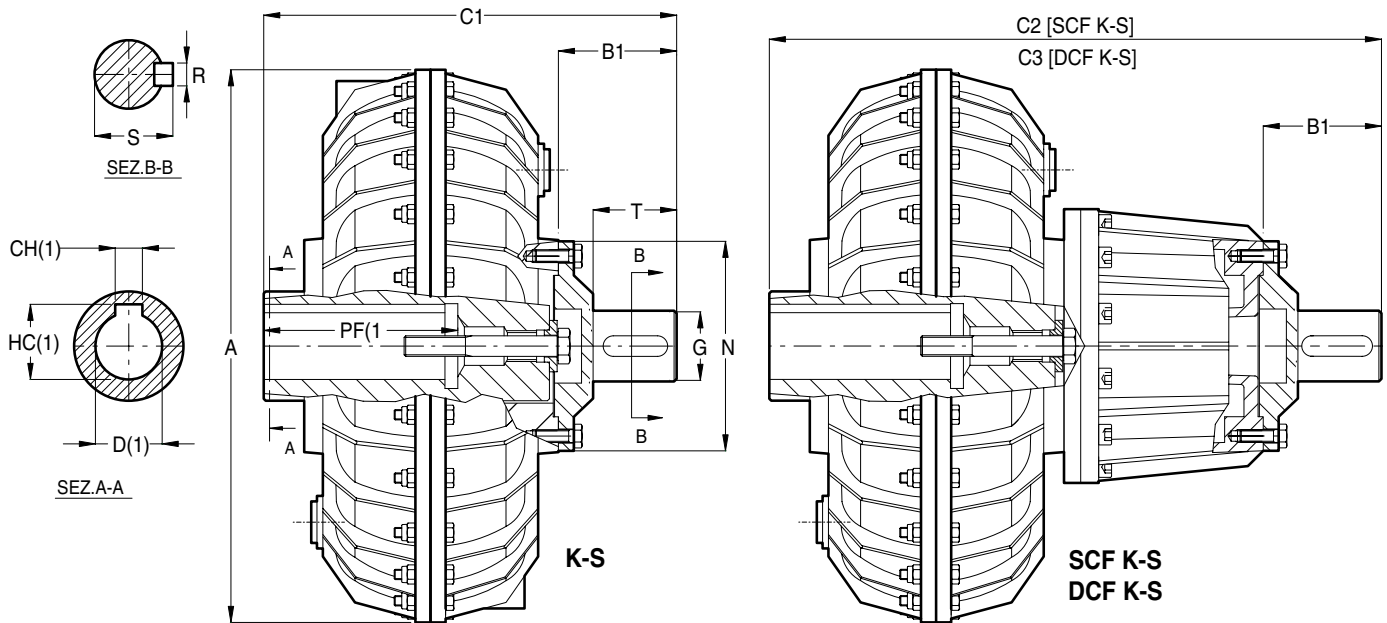

NOTE: (1) FOR BORE AND KEYWAY DIMENSIONS SEE SHEET 10-019D

Size	K-S											SCF K-S			DCF K-S		
	Dimensions mm.										Weight Kg. *	Dimensions mm.		Weight Kg. *	Dimensions mm.		Weight Kg. *
	Type	D	A	B1	C1	G h6	N	R	S	T		Type	C2		Type	C3	
10	K-1-S K-3-S	14-19-24 28	193	35	133 149	19	75	6	21,5	25	4,4	-	-	-	-	-	-
20	K-1-S K-3-S	19-24-28 38	230	44	169 179	24	94	8	27	32	6,7	-	-	-	-	-	-
30	K-1-S K-3-S K-4-S	28-38-42 48** 55	290	63	225 253 282	38	114	10	41	45	14,5	SCF K-2-S SCF K-3-S SCF K-4-S	280 308 337	16,9	DCF K-2-S DCF K-3-S DCF K-4-S	320 348 377	17,5 17,5 18,5
30P	K-1-S K-3-S K-4-S	28-38-42 48** 55	327	63	225 253 282	38	114	10	41	45	22,3	SCF K-2-S SCF K-3-S SCF K-4-S	280 308 337	24,7	DCF K-2-S DCF K-3-S DCF K-4-S	320 348 377	25,3 25,3 26,3
40P	K-1-S K-2-S	38-42-48-55 60	338	76	274	48	145	14	51,5	55	24,5	SCF K-2-S SCF K-2-S	280 332	28,2	DCF K-2-S DCF K-2-S	320 404	25,3 29,7
50	K-2-S	42-48-55-60-65	430	92	271	55	165	16	59	65	34	SCF K-2-S	351	39,8	DCF K-2-S	426	42
55	K-2-S K-3-S	42-48-55-60-65 75	430	92	303 302	55	165	16	59	65	44	SCF K-2-S SCF K-3-S	383 382	49,8	DCF K-2-S DCF K-3-S	458 457	52
60	K-2-S K-3-S	48-55-60-65-75 80	520	110	302 332	60	185	18	64	80	52	SCF K-2-S SCF K-3-S	392 422	60,4	DCF K-2-S DCF K-3-S	472 502	64
65	K-2-S	55-60-65-75-80	520	110	350	60	185	18	64	80	72	SCF K-2-S	440	80,4	DCF K-2-S	520	84
70P	K-2N-S K-3N-S	65-75-80-90 100	640	122	362 402	70	225	20	74,5	90	96	SCF K-2N-S SCF K-3N-S	472 512	109	DCF K-2N-S DCF K-3N-S	587 627	116
75P	K-2N-S K-3N-S	75-80-90 100	640	122	387 402	70	225	20	74,5	90	137	SCF K-2N-S SCF K-3N-S	497 512	150	DCF K-2N-S DCF K-3N-S	612 627	157
80P	K-2N-S K-3N-S	max. 110 max. 125***	810	145	415 431	80	270	22	85	110	197	SCF K-2N-S SCF K-3N-S	533 549	213	DCF K-2N-S DCF K-3N-S	633 649	225
85P	K-2N-S K-3N-S	max. 125 max. 135	810	145	485	80	270	22	85	110	269	SCF K-2N-S SCF K-3N-S	603	285	DCF K-2N-S DCF K-3N-S	703	297
90P	K-2-S K-3-S	max. 130 max. 140***	1000	220	584 684	110	550	28	116	180	418	SCF K-2-S SCF K-3-S	704 804	458	DCF K-2-S DCF K-3-S	784 884	473 513
95P	K-2-S K-3-S	max. 130 max. 140***	1000	220	699 806	160	550	40	169	180	595	SCF K-2-S SCF K-3-S	819 926	635	DCF K-2-S DCF K-3-S	899 1006	650 700
1200	K-2-S	max. 190	1300	290	752	180	550	45	190	250	1900	-	-	-	-	-	-

* Weight with oil - ** Reduced keyway - *** Depth of bore PF = 210 (for larger bores consult WESTCAR) - Standard bores in heavy type

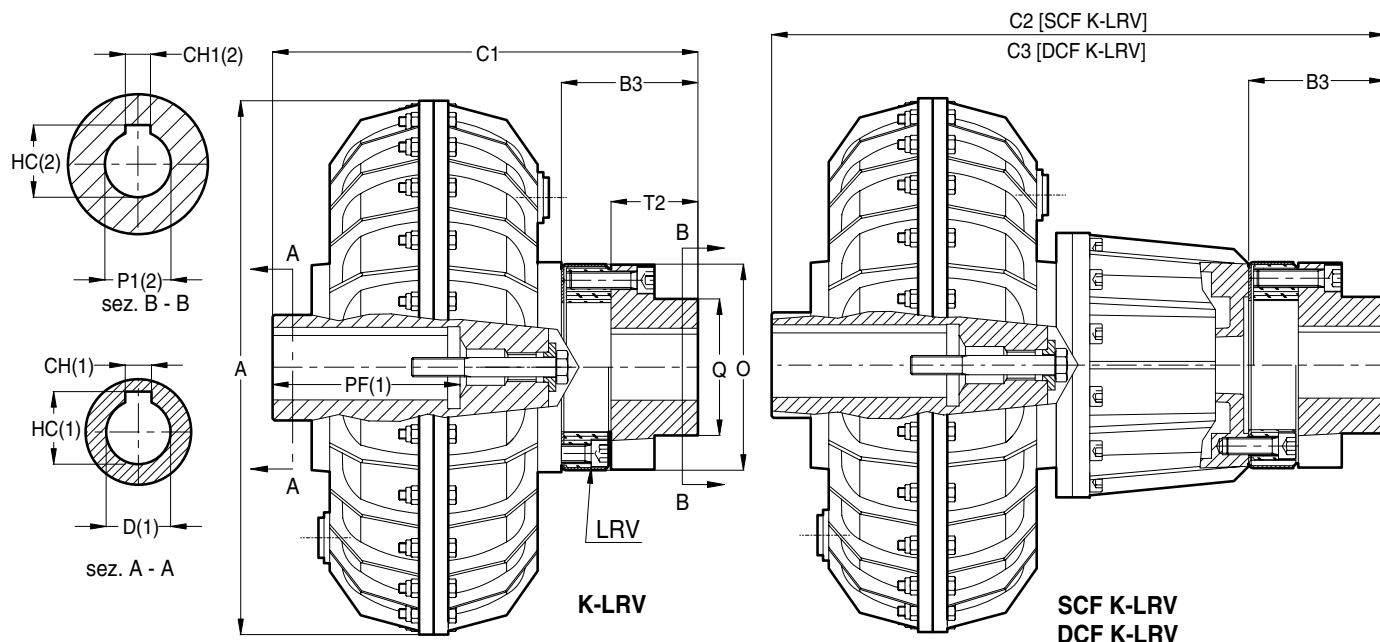

NOTE: (1) FOR BORE AND KEYWAY DIMENSIONS SEE SHEET 10-019D
(2) UPON REQUEST: BORE P1 MACHINED SEE SHEET 10-023A

Size.	K-LRV										SCF K-LRV			DCF K-LRV		
	Dimensions mm										Dimensions mm		Weight	Dimensions mm		Weight
	Type	D	A	B3	C1	O	P1 Max.	Q	T2	Kg.*	Type	C2	Kg.*	Type	C3	Kg.*
10	K-1-LRV-1 K-3-LRV-1	14-19-24 28	193	50	148 164	84	28	45	30	4,7	-	-	-	-	-	-
20	K-1-LRV-2 K-3-LRV-2	19-24-28 38	230	69	194 204	104	38	56	45	7,6	-	-	-	-	-	-
30	K-01-LRV-3	28-38-42	290	87	249	130	48	68	55	16,2	SCF K-02-LRV-3	304	18,6	DCF K-02-LRV-3	344	19,2
	K-03-LRV-3	48 **			277						332	18,6	DCF K-03-LRV-3	372	19,2	
	K-04-LRV-3	55			306						361	19,6	DCF K-04-LRV-3	401	20,2	
30P	K-01-LRV-3	28-38-42	327	87	249	130	48	68	55	24	SCF K-02-LRV-3	304	26,4	DCF K-02-LRV-3	344	27
	K-03-LRV-3	48 **			277						332	26,4	DCF K-03-LRV-3	372	27	
	K-04-LRV-3	55			306						361	27,4	DCF K-04-LRV-3	401	28	
40P	K-01-LRV-4 K-02-LRV-4	38-42-48-55 60	338	96	294	158	60	91	60	27,2	SCF K-02-LRV-4 SCF K-02-LRV-4	352 352	30,9	DCF K-02-LRV-4 DCF K-02-LRV-4	424 424	32,4
50	K-02-LRV-5	42-48-55-60-65	430	110	289	176	70	106	70	37,6	SCF K-02-LRV-5	369	43,4	DCF K-02-LRV-5	444	45,6
55	K-02-LRV-5	42-48-55-60-65	430	110	321	176	70	106	70	47,6	SCF K-02-LRV-5	401	53,4	DCF K-02-LRV-5	476	55,6
	K-03-LRV-5	75			320						400	53,4	DCF K-03-LRV-5	475	55,6	
60	K-02-LRV-6	48-55-60-65-75	520	124	316	195	80	121	80	59	SCF K-02-LRV-6	406	65,3	DCF K-02-LRV-6	486	69,7
	K-03-LRV-6	80			346						436	65,3	DCF K-03-LRV-6	516	69,7	
65	K-02-LRV-6	55-60-65-75-80	520	124	364	195	80	121	80	76,9	SCF K-02-LRV-6	454	85,3	DCF K-02-LRV-6	534	89,7
	K-03-LRV-6	80			364						454	85,3	DCF K-03-LRV-6	534	89,7	
70P	K-2N-LRV-7	65-75-80-90	640	140	380	236	100	146	90	104,3	SCF K-2N-LRV-7	490	117,3	DCF K-2N-LRV-7	605	124,3
	K-3N-LRV-7	100			420						530	117,3	DCF K-3N-LRV-7	645	124,3	
75P	See type "K-FRV"										See type "SCF K-FRV"			See type "DCF K-FRV"		
80P	Available with flexible coupling ROTOPIN AB - See type "K-AB"										See type "SCF K-AB"			See type "DCF K-AB"		
85P																
90P																
95P																
95P																

* Weight with oil - ** Reduced keyway - Standard bores in heavy type

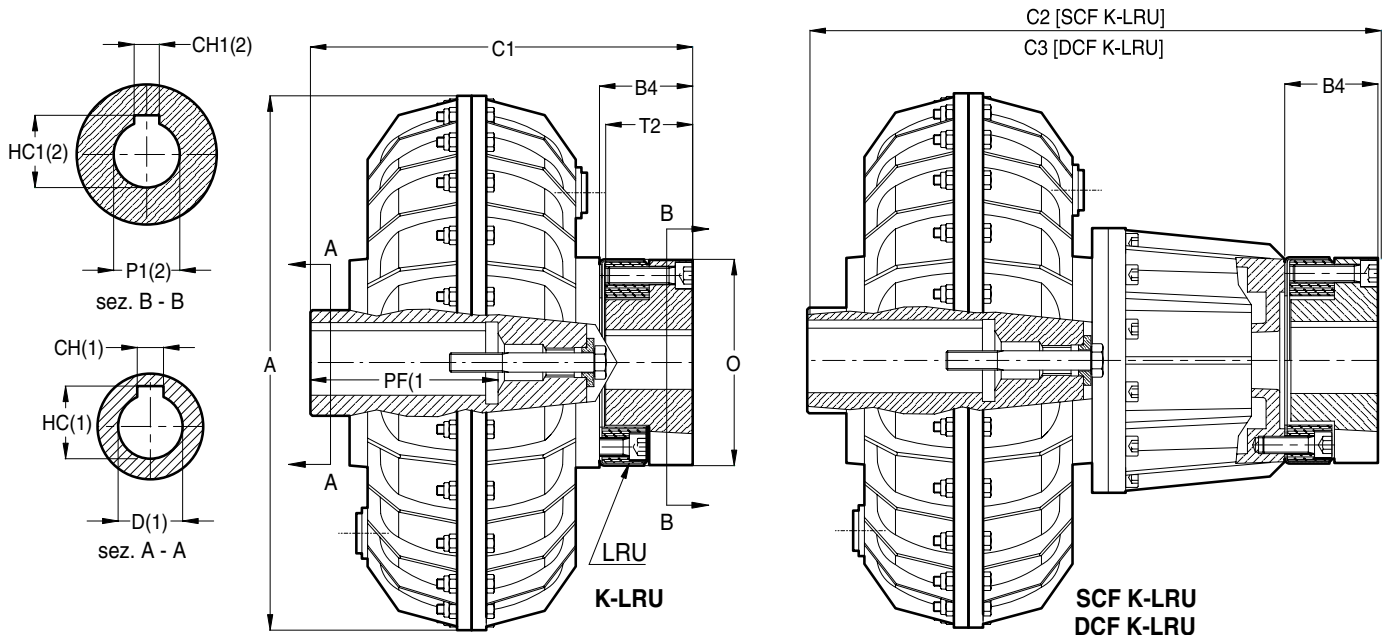

The rubber elements is not radially removable

NOTE: (1) FOR BORE AND KEYWAY DIMENSIONS SEE SHEET 10-019D
(2) UPON REQUEST: BORE P1 MACHINED SEE SHEET 10-023A

Size	K-LRU									SCF K-LRU			DCF K-LRU		
	Type	D	A	B4	C1	O	P1 Max.	T2	Kg. *	Type	C2	Kg. *	Type	C3	Kg. *
10	K-1-LRU-1 K-3-LRU-1	14-19-24 28	193	35	133 149	84	28	30	4,7	-	-	-	-	-	-
20	K-1-LRU-2 K-3-LRU-2	19-24-28 38	230	49	174 184	104	32	45	7,6	-	-	-	-	-	-
30	K-01-LRU-3	28-38-42	290	62	224	130	48	55	16,2	SCF K-02-LRU-3	279	18,6	DCF K-02-LRU-3	319	19,2
	K-03-LRU-3	48 **			252				16,2	SCF K-03-LRU-3	307	18,6	DCF K-03-LRU-3	347	19,2
	K-04-LRU-3	55			281				17,2	SCF K-04-LRU-3	336	19,6	DCF K-04-LRU-3	376	20,2
30P	K-01-LRU-3	28-38-42	327	62	224	130	48	55	24	SCF K-02-LRU-3	279	26,4	DCF K-02-LRU-3	319	27
	K-03-LRU-3	48 **			252				24	SCF K-03-LRU-3	307	26,4	DCF K-03-LRU-3	347	27
	K-04-LRU-3	55			281				25	SCF K-04-LRU-3	336	27,4	DCF K-04-LRU-3	376	28
40P	K-01-LRU-4 K-02-LRU-4	38-42-48-55 60	338	66	264	158	60	60	27,2	SCF K-02-LRU-4 SCF K-02-LRU-4	322 322	30,9	DCF K-02-LRU-4 DCF K-02-LRU-4	394 394	32,4
50	K-02-LRU-5	42-48-55-60-65	430	75	254	176	70	70	37,6	SCF K-02-LRU-5	334	43,4	DCF K-02-LRU-5	409	45,6
55	K-02-LRU-5	42-48-55-60-65	430	75	286	176	70	70	47,6	SCF K-02-LRU-5	366	53,4	DCF K-02-LRU-5	441	55,6
	K-03-LRU-5	75			285				365	440					
60	K-02-LRU-6	48-55-60-65-75	520	84	276	195	80	80	5,9	SCF K-02-LRU-6	366	65,3	DCF K-02-LRU-6	446	69,7
	K-03-LRU-6	80			306				396	476					
65	K-02-LRU-6	55-60-65-75-80	520	84	324	195	80	80	76,9	SCF K-02-LRU-6	414	85,3	DCF K-02-LRU-6	494	89,7
70P	K-2N-LRU-7	65-75-80-90	640	95	335	236	100	90	104,3	SCF K-2N-LRU-7	445	117,3	DCF K-2N-LRU-7	560	124,3
	K-3N-LRU-7	100			375				485	600					
75P	See type "K-FRV"									See type "SCF K-FRV"			See type "DCF K-FRV"		
80P	Available with flexible coupling ROTOPIN AB - See type "K-AB"									See type "SCF K-AB"			See type "DCF K-AB"		
85P															
90P															
95P															

* Weight with oil - ** Reduced keyway - Standard bores in heavy type

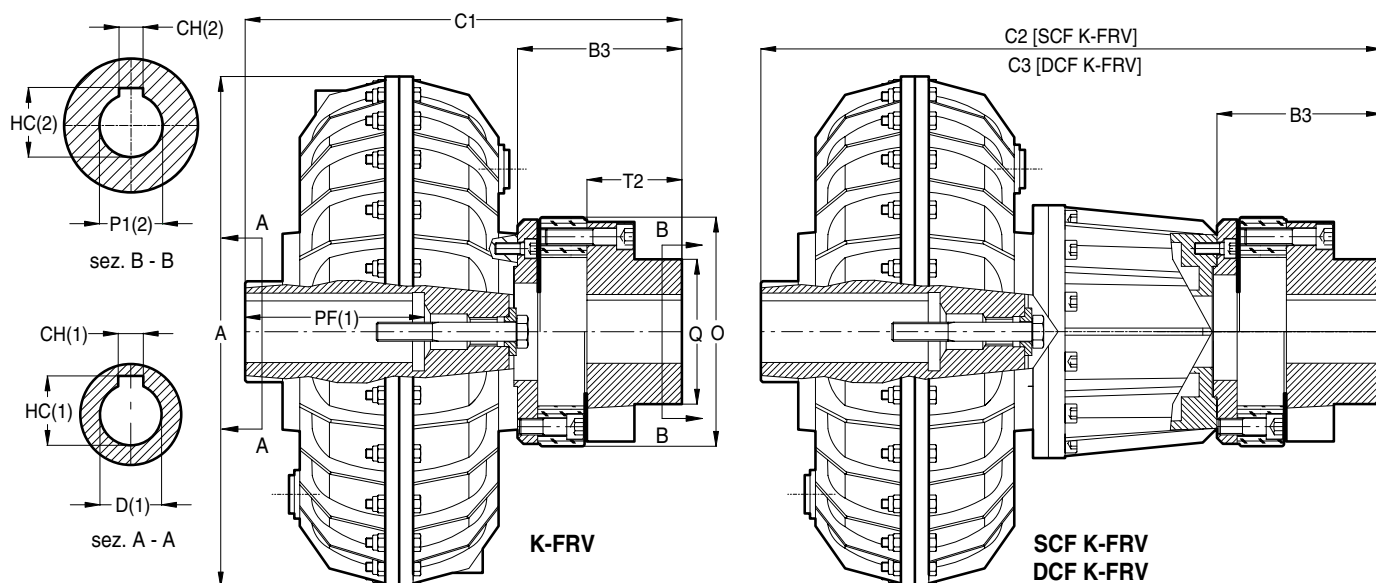

NOTE: (1) FOR BORE AND KEYWAY DIMENSIONS SEE SHEET 10-019D (2) UPON REQUEST: BORE P1 MACHINED SEE SHEET 10-023A

Size	K-FRV										SCF K-FRV			DCF K-FRV		
	Dimensions mm									Weight Kg _*	Dimensions mm		Weight Kg _*	Dimensions mm		Weight Kg _*
	Type	D	A	B3	C1	O	P1 Max.	Q	T2		Type	C2		Type	C3	
10	K-1-FRV-2 K-3-FRV-2	14-19-24 28	193	77	175 191	100	38	56	45	5,8	-	-	-	-	-	-
20	K-1-FRV-3 K-3-FRV-3	19-24-28 38	230	98	223 233	126	48	68	55	9,6	-	-	-	-	-	-
30	K-1-FRV-4 K-3-FRV-4 K-4-FRV-4	28-38-42 48 ** 55	290	111	273 301 330	153	60	91	60	19,5 19,5 20,5	SCF K-2-FRV-4 SCF K-3-FRV-4 SCF K-4-FRV-4	328 356 385	21,9 21,9 22,9	DCF K-2-FRV-4 DCF K-3-FRV-4 DCF K-4-FRV-4	368 396 425	22,5 22,5 23,5
30P	K-1-FRV-4 K-3-FRV-4 K-4-FRV-4	28-38-42 48 ** 55	327	111	273 301 330	153	60	91	60	27,3 27,3 28,3	SCF K-2-FRV-4 SCF K-3-FRV-4 SCF K-4-FRV-4	328 356 385	29,7 29,7 30,7	DCF K-2-FRV-4 DCF K-3-FRV-4 DCF K-4-FRV-4	368 396 425	30,3 30,3 31,3
40P	K-1-FRV-5 K-2-FRV-5	38-42-48-55 60	338	125	323	170	70	106	70	31	SCF K-2-FRV-5 SCF K-2-FRV-5	381	34,7	DCF K-2-FRV-5 DCF K-2-FRV-5	453	36,2
50	K-2-FRV-6	42-48-55-60-65	430	139	318	190	80	121	80	42,5	SCF K-2-FRV-6	398	48,3	DCF K-2-FRV-6	473	50,5
55	K-2-FRV-6 K-3-FRV-6	42-48-55-60-65 75	430	139	350 349	190	80	121	80	52,5	SCF K-2-FRV-6 SCF K-3-FRV-6	430 429	58,3	DCF K-2-FRV-6 DCF K-3-FRV-6	505 504	60,5
60	K-2-FRV-7 K-3-FRV-7	48-55-60-65-75 80	520	163	355 385	232	100	146	90	69	SCF K-2-FRV-7 SCF K-3-FRV-7	445 475	77,4	DCF K-2-FRV-7 DCF K-3-FRV-7	525 555	81
65	K-2-FRV-7	55-60-65-75-80	520	163	403	232	100	146	90	89	SCF K-2-FRV-7	493	97,4	DCF K-2-FRV-7	573	101
70P	K-2N-FRV-8 K-3N-FRV-8	65-75-80-90 100	640	194	434 474	271	110	156	110	123	SCF K-2N-FRV-8 SCF K-3N-FRV-8	544 584	136	DCF K-2N-FRV-8 DCF K-3N-FRV-8	659 699	143
75P	K-2N-FRV-8 K-3N-FRV-8	75-80-90 100	640	194	459 474	271	110	156	110	164	SCF K-2N-FRV-8 SCF K-3N-FRV-8	569 584	177	DCF K-2N-FRV-8 DCF K-3N-FRV-8	684 699	184
75P	K-2N-FRV-8x2 K-3N-FRV-8x2	75-80-90 100	640	246	511 526	271	110	156	110	174	SCF K-2N-FRV-8x2 SCF K-3N-FRV-8x2	621 636	187	DCF K-2N-FRV-8x2 DCF K-3N-FRV-8x2	736 751	194
80P	Available with flexible coupling ROTOPIN AB - See type "K-AB"										See type "SCF K-AB"			See type "DCF K-AB"		
85P																
90P																
95P																

* Weight with oil - ** Reduced keyway - Standard bores in heavy type

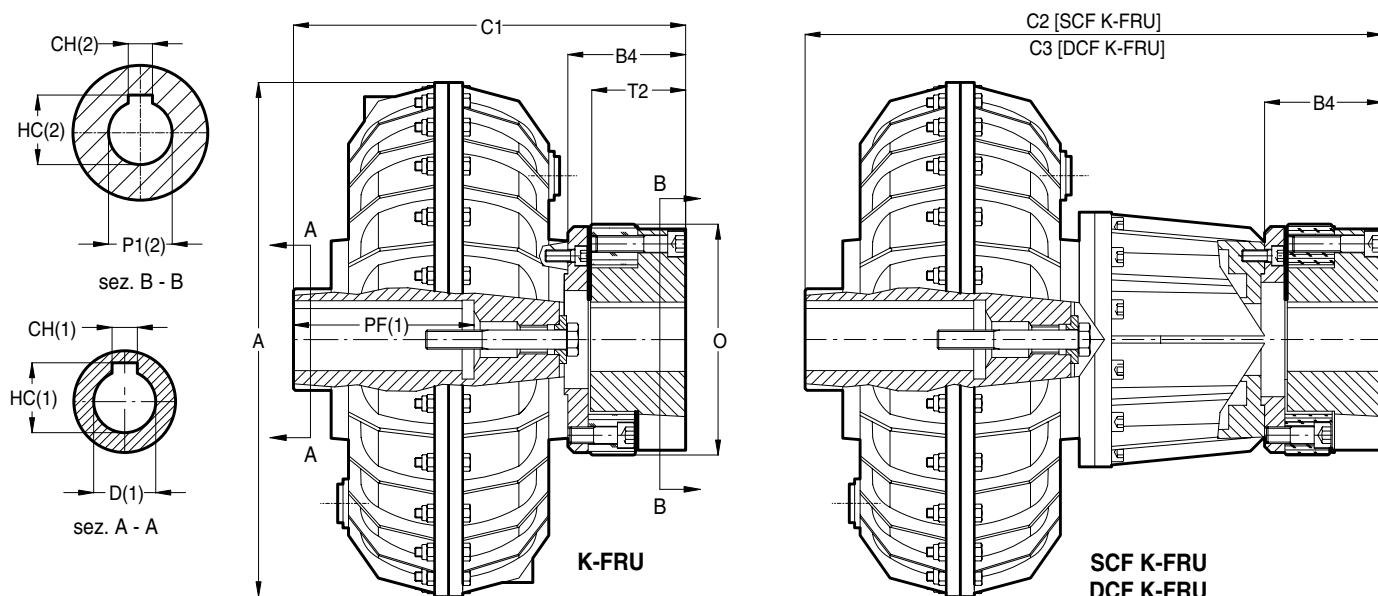

The rubber elements is not radially removable

NOTE: (1) FOR BORE AND KEYWAY DIMENSIONS SEE SHEET 10-019D (2) UPON REQUEST: BORE P1 MACHINED SEE SHEET 10-023A

Size	K-FRU									SCF K-FRU			DCF K-FRU		
	Type	Dimensions mm.							Weight	Type	C2	Weight	Type	C3	Weight
		D	A	B4	C1	O	P1 Max.	T2	Kg *			Kg. *			Kg. *
10	K-1-FRU-2 K-3-FRU-2	14-19-24 28	193	60	158 174	100	38	45	5,8	-	-	-	-	-	-
20	K-1-FRU-3 K-3-FRU-3	19-24-28 38	230	73	198 208	126	48	55	9,6	-	-	-	-	-	-
30	K-1-FRU-4 K-3-FRU-4 K-4-FRU-4	28-38-42 48 ** 55	290	81	245 273 302	153	60	60	19,5 19,5 20,5	SCF K-2-FRU-4 SCF K-3-FRU-4 SCF K-4-FRU-4	300 328 357	21,9 21,9 22,9	DCF K-2-FRU-4 DCF K-3-FRU-4 DCF K-4-FRU-4	340 368 397	22,5 22,5 23,5
30P	K-1-FRU-4 K-3-FRU-4 K-4-FRU-4	28-38-42 48 ** 55	327	81	245 273 302	153	60	60	27,3 27,3 28,3	SCF K-2-FRU-4 SCF K-3-FRU-4 SCF K-4-FRU-4	300 328 357	29,7 29,7 30,7	DCF K-2-FRU-4 DCF K-3-FRU-4 DCF K-4-FRU-4	340 368 397	30,3 30,3 31,3
40P	K-1-FRU-5 K-2-FRU-5	38-42-48-55 60	338	90	288	170	70	70	31	SCF K-2-FRU-5 SCF K-2-FRU-5	346 346	34,7 34,7	DCF K-2-FRU-5 DCF K-2-FRU-5	418	36,2
50	K-2-FRU-6	42-48-55-60-65	430	99	278	190	80	80	42,5	SCF K-2-FRU-6	358	48,3	DCF K-2-FRU-6	433	50,5
55	K-2-FRU-6 K-3-FRU-6	42-48-55-60-65 75	430	99	310 309	190	80	80	52,5	SCF K-2-FRU-6 SCF K-3-FRU-6	390 389	58,3 58,3	DCF K-2-FRU-6 DCF K-3-FRU-6	465 464	60,5
60	K-2-FRU-7 K-3-FRU-7	48-55-60-65-75 80	520	118	310 340	232	100	90	69	SCF K-2-FRU-7 SCF K-3-FRU-7	400 430	77,4 77,4	DCF K-2-FRU-7 DCF K-3-FRU-7	480 510	81
65	K-2-FRU-7	55-60-65-75-80	520	118	358	232	100	90	89	SCF K-2-FRU-7	448	97,4	DCF K-2-FRU-7	528	101
70P	K-2N-FRU-8 K-3N-FRU-8	65-75-80-90 100	640	139	379 419	271	110	110	123	SCF K-2N-FRU-8 SCF K-3N-FRU-8	489 529	136 136	DCF K-2N-FRU-8 DCF K-3N-FRU-8	604 644	143
75P	K-2N-FRU-8 K-3N-FRU-8	75-80-90 100	640	139	404 419	271	110	110	164	SCF K-2N-FRU-8 SCF K-3N-FRU-8	514 529	177 177	DCF K-2N-FRU-8 DCF K-3N-FRU-8	629 644	184
75P	K-2N-FRU-8x2 K-3N-FRU-8x2	75-80-90 100	640	191	456 471	271	110	110	174	SCF K-2N-FRU-8x2 SCF K-3N-FRU-8x2	566 581	187 187	DCF K-2N-FRU-8x2 DCF K-3N-FRU-8x2	681 696	194
80P	Available with flexible coupling ROTOPIN AB - See type "K-AB"									See type "SCF K-AB"			See type "DCF K-AB"		
85P															
90P															
95P															

* Weight with oil - ** Reduced keyway - Standard bores in heavy type

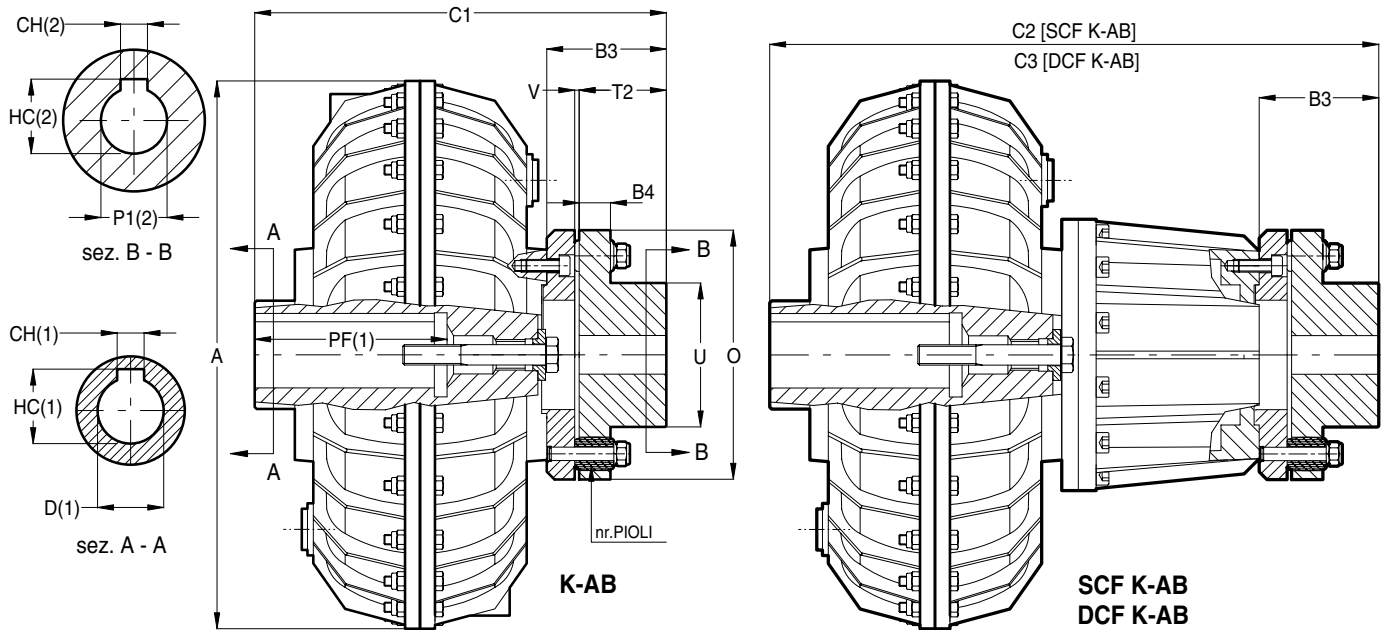

NOTE: (1) FOR BORE AND KEYWAY DIMENSIONS SEE SHEET 10-019D (2) UPON REQUEST: BORE P1 MACHINED SEE SHEET 10-023A

Size	K-AB												SCF K-AB			DCF K-AB			
	Dimensions mm.											Weight	Dimensions mm.		Weight	Dimensions mm.		Weight	
	D	A	B3	B4	C1	nr.	O	P1 Max.	T2	U	V	Kg *	Type	C2	Kg *	Type	C3	Kg *	
80P	K-2N-AB-8	max. 110	810	196	65	466	8	330	110	140	170	6	240	SCF K-2N-AB-8	584	256	DCF K-2N-AB-8	684	268
	K-3N-AB-8	max. 125***												SCF K-3N-AB-8	600		DCF K-3N-AB-8	700	
85P	K-2N-AB-8M	max. 125	810	226	65	566	12	400	155	170	236	6	367	SCF K-2N-AB-8M	684	383	DCF K-2N-AB-8M	784	395
	K-3N-AB-8M	max. 135												SCF K-3N-AB-8M			684		
90P	K-2-AB-9	max. 130	1000	318	82	682	14	550	180	250	290	6	600	SCF K-2-AB-9	742	640	DCF K-2-AB-9	822	655
	K-3-AB-9	max. 140***				782								SCF K-3-AB-9	842		680	DCF K-3-AB-9	
95P	K-2-AB-9	max. 130	1000	318	82	797	14	550	180	250	290	6	755	SCF K-2-AB-9	917	795	DCF K-2-AB-9	997	810
	K-3-AB-9	max. 140***				904								SCF K-3-AB-9	1024		845	DCF K-3-AB-9	
1200	K-2-AB-9	max. 190	1300	318	82	780	14	550	180	250	290	6	2050	-	-	-	-	-	-

* Weight with oil - *** Depth of bore PF = 210 (for larger bores consult WESTCAR)

For “REVERSE MOUNTING” see type “KK”

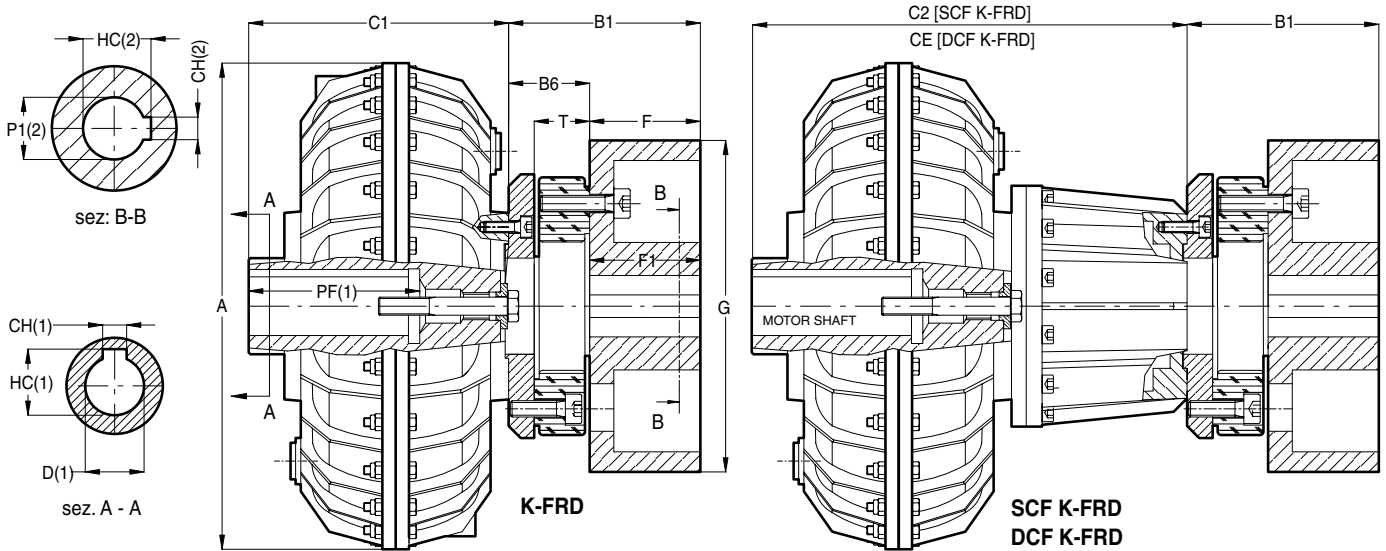

NOTE: (1) FOR BORE AND KEYWAY DIMENSIONS SEE SHEET 10-019D

(2) UPON REQUEST: BORE P1 MACHINED SEE SHEET 10-023A

Size	K-FRD								SCF K-FRD			DCF K-FRD			
	Dimensions mm								Weight	Dimensions mm		Weight	Dimensions mm		Weight
	Type	D	A	B6	C1	P1 Max.	T	Kg.*		Type	C2		Kg.*	Type	
20	K-1-FRD-3 K-3-FRD-3	19-24-28 38	230	43	125 135	48	28	7,6	-	-	-	-	-	-	
30	K-1-FRD-4 K-3-FRD-4 K-4-FRD-4	28-38-42 48** 55	290	51	162 190 219	60	34	15,8	SCF K-2-FRD-4 SCF K-3-FRD-4 SCF K-4-FRD-4	217 245 274	18,2	DCF K-2-FRD-4 DCF K-3-FRD-4 DCF K-4-FRD-4	257 285 314	18,8	
30P	K-1-FRD-4 K-3-FRD-4 K-4-FRD-4	28-38-42 48** 55	327	51	162 190 219	60	34	23,6	SCF K-2-FRD-4 SCF K-3-FRD-4 SCF K-4-FRD-4	217 245 274	26	DCF K-2-FRD-4 DCF K-3-FRD-4 DCF K-4-FRD-4	257 285 314	26,6	
40P	K-1-FRD-5 K-2-FRD-5	38-42-48-55 60	338	55	198	70	38	25,3	SCF K-2-FRD-5 SCF K-2-FRD-5	256	29	DCF K-2-FRD-5 DCF K-2-FRD-5	328	30,5	
50	K-2-FRD-6	42-48-55-60-65	430	59	179	80	42	34	SCF K-2-FRD-6	259	39,8	DCF K-2-FRD-6	334	42	
55	K-2-FRD-6 K-3-FRD-6	42-48-55-60-65 75	430	59	211 210	80	42	44	SCF K-2-FRD-5 SCF K-3-FRD-6	291 290	49,8	DCF K-2-FRD-6 DCF K-3-FRD-6	366 365	52	
60	K-2-FRD-7 K-3-FRD-7	48-55-60-65-75 80	520	73	192 222	100	48	54,9	SCF K-2-FRD-7 SCF K-3-FRD-7	282 312	63,3	DCF K-2-FRD-7 DCF K-3-FRD-7	362 392	66,9	
65	K-2-FRD-7	55-60-65-75-80	520	73	240	100	48	74,9	SCF K-2-FRD-7	330	83,3	DCF K-2-FRD-7	410	86,9	
70P	K-2N-FRD-8 K-3N-FRD-8	65-75-80-90 100	640	84	240 280	110	56	91	SCF K-2N-FRD-8 SCF K-3N-FRD-8	350 390	114	DCF K-2N-FRD-8 DCF K-3N-FRD-8	465 505	121	
75P	K-2N-FRD-8 K-3N-FRD-8	75-80-90 100	640	84	265 280	110	56	142	SCF K-2N-FRD-8 SCF K-3N-FRD-8	375 390	155	DCF K-2N-FRD-8 DCF K-3N-FRD-8	490 505	162	
75P	K-2N-FRD-8x2 K-3N-FRD-8x2	75-80-90 100	640	136	317 332	110	56	152	SCF K-2N-FRD-8x2 SCF K-3N-FRD-8x2	427 442	165	DCF K-2N-FRD-8x2 DCF K-3N-FRD-8x2	542 557	172	
80P	Available with flexible coupling ROTOPIN AB - See type “K-AFF”								See type “SCF K-AFF”			See type “DCF K-AFF”			
85P															
90P															
95P															

BRAKE DRUMS “D” DIMENSIONS

Size	D-3				D-4				D-5				D-6				D-7				D-8			
B1	103	118	138	161	126	146	169	130	150	173	205	245	134	154	177	209	249	191	223	263	234	274		
Ø G	160	200	250	315	200	250	315	200	250	315	400	500	200	250	315	400	500	315	400	500	400	500		
F=F1	60	75	95	118	75	95	118	75	95	118	150	190	75	95	118	150	190	118	150	190	150	190		
Kg.	4,7	7,2	13,1	22,8	8,6	14,8	25	9,3	15,8	26,2	45,1	76,2	10,8	17,8	28,7	48,4	80,5	32,6	53,5	87	55,7	90		

* Weight with oil without Brake Drum - ** Reduced keyway - Standard bores in heavy type

For “REVERSE MOUNTING” see type “KK”

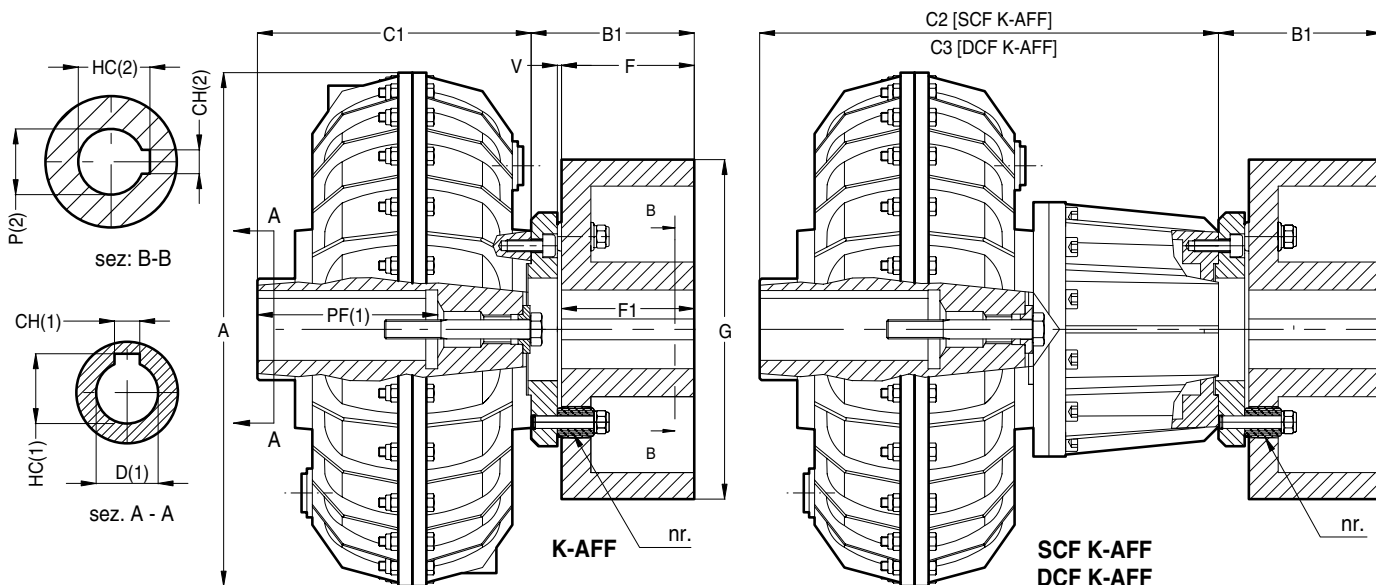

NOTE: (1) FOR BORE AND KEYWAY DIMENSIONS SEE SHEET 10-019D

(2) UPON REQUEST: BORE P1 MACHINED SEE SHEET 10-023A

Size	K-AFF								SCF K-AFF			DCF K-AFF		
	Dimensions mm							Weight Kg *	Dimensions mm		Weight Kg *	Dimensions mm		Weight Kg *
	Type	D	A	C1	nr.	P1 Max.	V		Type	C2		Type	C3	
50	K-2-AFF-5	42-48-55-60-65	430	179	8	70	4	35	SCF K-2-AFF-5	259	40,8	DCF K-2-AFF-5	334	43
55	K-2-AFF-5	42-48-55-60-65	430	211	8	70	4	45	SCF K-2-AFF-5	291	50,8	DCF K-2-AFF-5	366	53
	K-3-AFF-5	75	210	8	70	4	45	SCF K-3-AFF-5	290	50,8	DCF K-3-AFF-5	365	53	
60	K-2-AFF-6	48-55-60-65-75	520	192	8	85	4	54	SCF K-2-AFF-6	282	62,4	DCF K-2-AFF-6	362	66
	K-3-AFF-6	80	222	8	85	4	54	SCF K-3-AFF-6	312	62,4	DCF K-3-AFF-6	392	66	
65	K-2-AFF-6	55-60-65-75-80	520	240	8	85	4	74	SCF K-2-AFF-6	330	82,4	DCF K-2-AFF-6	410	86
70P	K-2N-AFF-8/7	75-80-90	640	240	8	105	5	101	SCF K-2N-AFF-7	350	114	DCF K-2N-AFF-7	465	121
	K-3N-AFF-8/7	100	280	8	105	5	101	SCF K-3N-AFF-7	390	114	DCF K-3N-AFF-7	505	121	
75P	K-2N-AFF-8/7	80-90	640	265	8	105	5	142	SCF K-2N-AFF-7	375	155	DCF K-2N-AFF-7	490	162
	K-3N-AFF-8/7	100	280	8	105	5	142	SCF K-3N-AFF-7	390	155	DCF K-3N-AFF-7	505	162	
80P	K-2N-AFF-8	max. 110	810	270	8	110	6	210	SCF K-2N-AFF-8	388	226	DCF K-2N-AFF-8	488	238
	K-3N-AFF-8	max. 125***	286	8	110	6	210	SCF K-3N-AFF-8	404	226	DCF K-3N-AFF-8	504	238	
85P	K-2N-AFF-8M	max. 125	810	340	12	160	6	302	SCF K-2N-AFF-8M	458	318	DCF K-2N-AFF-8M	558	330
	K-3N-AFF-8M	max. 135	340	12	160	6	302	SCF K-3N-AFF-8M	458	318	DCF K-3N-AFF-8M	558	330	
90P	K-2-AFF-9	max. 130	1000	364	14	180	6	450	SCF K-2-AFF-9	424	490	DCF K-2-AFF-9	504	505
	K-3-AFF-9	max. 140***	764	14	180	6	450	SCF K-3-AFF-9	524	490	DCF K-3-AFF-9	604	545	
95P	K-2-AFF-9	max. 130	1000	479	14	180	6	605	SCF K-2-AFF-9	599	645	DCF K-2-AFF-9	679	660
	K-3-AFF-9	max. 140***	586	14	180	6	605	SCF K-3-AFF-9	706	645	DCF K-3-AFF-9	786	710	

BRAKE DRUMS “D” DIMENSIONS

Size	FF-5			FF-6			FF-8/7 FF-8			FF-8M			FF-9		
B1	124	147	179	156	188	228	206	246	292	206	246	292	255	304	333
Ø G	250	315	400	315	400	500	400	500	630	400	500	630	500	630	710
F=F1	95	118	150	118	150	190	150	190	236	150	190	236	190	236	265
Kg.	20	33	50	38	56	89	75	108	168	85	118	178	236	296	365

* Weight with oil - ** Reduced keyway - *** Depth of bore PF = 210 (for larger bores consult WESTCAR) - Standard bores in heavy type

For “REVERSE MOUNTING” see type “KK”

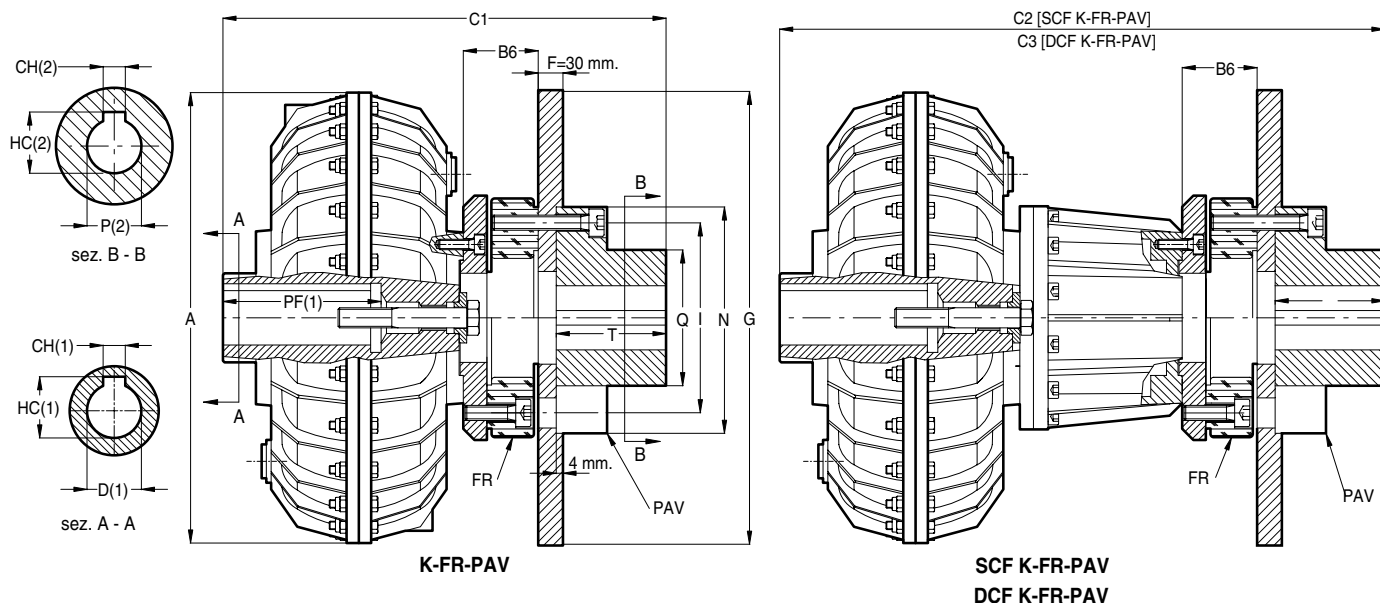

NOTE: (1) FOR BORE AND KEYWAY DIMENSIONS SEE SHEET 10-019D (2) UPON REQUEST: BORE P1 MACHINED SEE SHEET 10-023A

Size	K-FR-PAV											Weight Kg.*	SCF K-FR-PAV			DCF K-FR-PAV		
	Dimensions mm												Dimensions mm			Dimensions mm		
	Type	D	A	B6	C1	P1 Max.	T	Q	I	N	Ø G		Type	C2	Weight Kg.*	Type	C3	Weight Kg.*
10	K-1-FR-PAV-2	14-19-24	193	35	204	38	45	55	78	94	200	-	-	-	-	-	-	
	K-3-FR-PAV-2	28			220													
20	K-1-FR-PAV-3	19-24-28	230	43	249	48	55	69	100	118	250-315	-	-	-	-	-	-	
	K-3-FR-PAV-3	38			259													
30	K-1-FR-PAV-4	28-38-42	290	51	299	60	60	91	125	145	250-315	SCF K-1-FR-PAV-4	354	21,9	DCF K-1-FR-PAV-4	394	22,5	
	K-3-FR-PAV-4	48 **			327							SCF K-3-FR-PAV-4	382		DCF K-3-FR-PAV-4	422		
	K-4-FR-PAV-4	55			356							SCF K-4-FR-PAV-4	411		DCF K-4-FR-PAV-4	451		
30P	K-1-FR-PAV-4	28-38-42	290	51	299	60	60	91	125	145	250-315	SCF K-1-FR-PAV-4	354	29,7	DCF K-1-FR-PAV-4	394	30,3	
	K-3-FR-PAV-4	48 **			327							SCF K-3-FR-PAV-4	382		DCF K-3-FR-PAV-4	422		
	K-4-FR-PAV-4	55			356							SCF K-4-FR-PAV-4	411		DCF K-4-FR-PAV-4	451		
40P	K-1-FR-PAV-5	42-48-55	338	55	349	70	70	106	140	165	315-355-400	SCF K-2-FR-PAV-5	407	34,7	DCF K-2-FR-PAV-5	479	36,2	
	K-2-FR-PAV-5	60																
50	K-2-FR-PAV-6	42-48-55-60-65	430	59	344	80	80	121	160	185	315-355-400	SCF K-2-FR-PAV-6	424	48,3	DCF K-2-FR-PAV-6	499	50,5	
55	K-2-FR-PAV-6	55-60-65-75	430	59	376	80	80	121	160	185	315-355-400	SCF K-2-FR-PAV-6	456	58,3	DCF K-2-FR-PAV-6	531	60,5	
	K-3-FR-PAV-6				375							SCF K-3-FR-PAV-6	455		DCF K-3-FR-PAV-6	530		
60	K-2-FR-PAV-7	60-65-75-80	520	73	381	100	90	146	195	225	400-450-500	SCF K-2-FR-PAV-7	471	77,4	DCF K-2-FR-PAV-7	551	81	
	K-3-FR-PAV-7				411							SCF K-3-FR-PAV-7	501		DCF K-3-FR-PAV-7	581		
65	K-2-FR-PAV-7	55-60-65-75-80	520	73	429	100	90	146	195	225	400-450-500	SCF K-2N-FR-PAV-7	519	97,4	DCF K-2N-FR-PAV-7	599	101	
70P	K-2N-FR-PAV-8	75-80-90	640	84	460	110	110	156	225	270	500-560-630	SCF K-2N-FR-PAV-8	570	136	DCF K-2N-FR-PAV-8	685	143	
	K-3N-FR-PAV-8	100			500							SCF K-3N-FR-PAV-8	610		DCF K-3N-FR-PAV-8	725		
75P	K-2N-FR-PAV-8	75-80-90	640	84	485	110	110	156	225	270	500-560-630	SCF K-2N-FR-PAV-8	595	177	DCF K-2N-FR-PAV-8	710	184	
	K-3N-FR-PAV-8	100			500						710	SCF K-3N-FR-PAV-8	610		DCF K-3N-FR-PAV-8	725		
75P	K-2N-FR-PAV-8x2	75-80-90	640	136	537	110	110	156	225	270	500-560-630	SCF K-2N-FR-PAV-8x2	647	187	DCF K-2N-FR-PAV-8x2	762	194	
	K-3N-FR-PAV-8x2	100			552						710	SCF K-3N-FR-PAV-8x2	662		DCF K-3N-FR-PAV-8x2	777		

BRAKE DISC “PA”

Ø G	200	250	315	355	400	450	500	560	630	710
F	30	30	30	30	30	30	30	30	30	30
Weight Kg.	3,7	5,7	9,1	12,5	14,7	18	23	28	36	45

Different disc thickness “F” is available on request – * Weight with oil without brake disc “PA” – ** Reduced keyway – Standard bores in heavy type

REVERSE ASSEMBLY

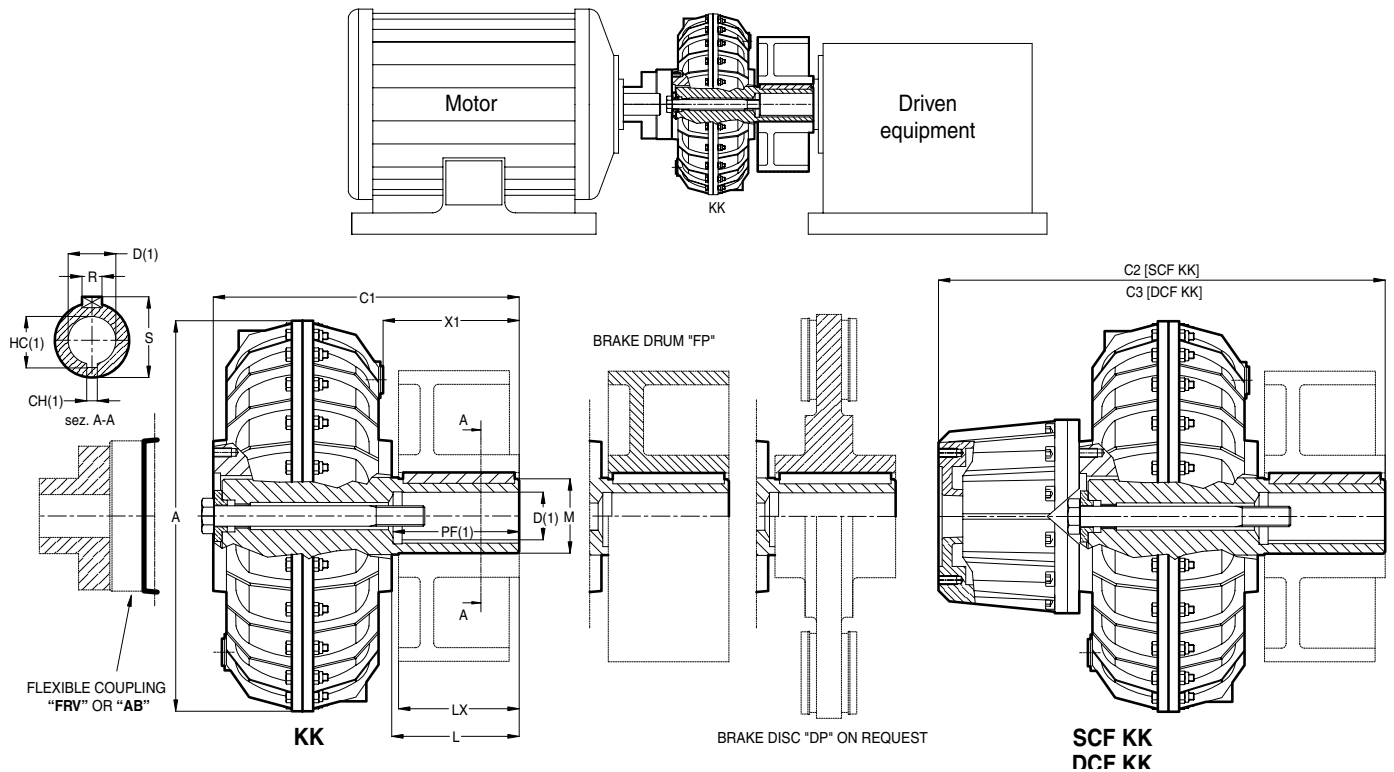

NOTE: (1) FOR BORE AND KEYWAY DIMENSIONS SEE SHEET 10-019D

Size	KK											SCF KK			DCF KK		
	Type	D Max.	A	C1	L	LX	M	R	S	X1	Weight Kg.*	Type	C2	Weight Kg.*	Type	C3	Weight Kg.*
20	K-2 K 70	28	230	185	70	60	44	10	47,3	77	6,2	..	--	--	--	--	--
30	K-2 K 68	42	290	218	68	60	57	12	60,3	77	13,6	SCF K-2 K 68	273	16	DCF K-2 K 68	313	16,6
	K-2 K 88			238	88	75				97	13,8	SCF K-2 K 88	293	16,2	DCF K-2 K 88	333	16,8
	K-2 K 112			262	112	95				121	14	SCF K-2 K 112	317	16,4	DCF K-2 K 112	356	17
30P	K-2 K 68	42	327	218	68	60	57	12	60,3	77	21,4	SCF K-2 K 68	273	23,8	DCF K-2 K 68	313	24,4
	K-2 K 88			238	88	75				97	21,6	SCF K-2 K 88	293	24	DCF K-2 K 88	333	24,6
	K-2 K 112			262	112	95				121	21,8	SCF K-2 K 112	317	24,2	DCF K-2 K 112	356	24,8
40P	K-2 K 90	60	338	273	90	75	77	16	81,3	114	23	SCF K-2 K 90	331	26,7	DCF K-2 K 90	403	28,2
	K-2 K 118			301	118	115				142	23,5	SCF K-2 K 118	359	27,2	DCF K-2 K 118	431	28,7
50	K-2 K 90	65	430	234	90	86	85	18	89,3	97	32,5	SCF K-2 K 90	314	38,3	DCF K-2 K 90	389	40,5
	K-2 K 120			264	120	118				127	33,5	SCF K-2 K 120	344	39,3	DCF K-2 K 120	419	41,5
	K-2 K 155			299	155	150				162	34,5	SCF K-2 K 155	379	40,3	DCF K-2 K 155	454	42,5
55	K-2 K 90	65	430	286	90	86	85	18	89,3	97	42	SCF K-2 K 90	366	47,8	DCF K-2 K 90	441	50
	K-2 K 120			316	120	118				127	43	SCF K-2 K 120	396	48,8	DCF K-2 K 120	471	51
	K-2 K 155			351	155	150				162	44	SCF K-2 K 155	431	49,8	DCF K-2 K 155	506	52
60	K-2 K 130	80	520	302	130	118	107	20	111,9	136	50	SCF K-2 K 130	392	58,4	DCF K-2 K 130	472	62
	K-2 K 170			342	170	150				176	53	SCF K-2 K 170	432	61,4	DCF K-2 K 170	512	65
	K-2 K 230			402	230	190				236	56	SCF K-2 K 230	492	64,4	DCF K-2 K 230	572	68
65	K-2 K 130	80	520	350	130	118	107	20	111,9	136	69	SCF K-2 K 130	440	77,4	DCF K-2 K 130	520	71
	K-2 K 170			390	170	150				176	72	SCF K-2 K 170	480	80,4	DCF K-2 K 170	560	74
	K-2 K 220			440	220	190				226	76	SCF K-2 K 220	530	84,4	DCF K-2 K 220	610	78
	K-2 K 255			475	255	236				261	79	SCF K-2 K 255	565	87,4	DCF K-2 K 255	645	81

* Weight with oil

REVERSE ASSEMBLY

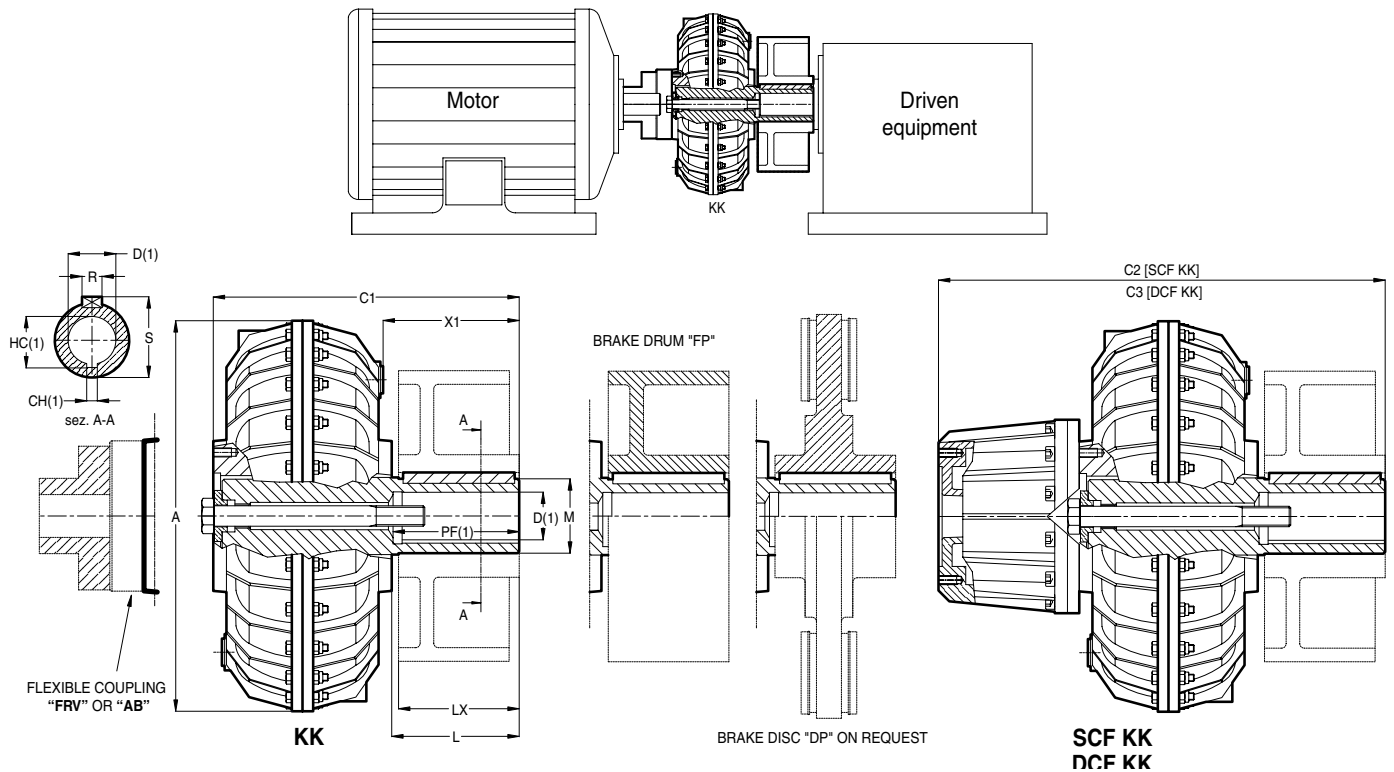

NOTE: (1) FOR BORE AND KEYWAY DIMENSIONS SEE SHEET 10-019D

Size	KK										SCF KK			DCF KK			
	Dimensions mm										Weight	Dimensions mm		Weight	Dimensions mm		Weight
	Type	D Max.	A	C1	L	LX	M	R	S	X1		Type	C2		Type	C3	
70P	K-2N K 155	90	640	345	155	150	128	25	133,4	159	105	SCF K-2N K 155	455	118	DCF K-2N K 155	570	125
	K-2N K 195			385	195	190				199	108	SCF K-2N K 195	495	121	DCF K-2N K 195	610	128
	K-2N K 240			430	240	236				244	112	SCF K-2N K 240	540	125	DCF K-2N K 240	655	132
	K-2N K 270			460	270	265				274	115	SCF K-2N K 270	570	128	DCF K-2N K 270	685	135
	K-2N K 305			495	305	300				309	118	SCF K-2N K 305	605	131	DCF K-2N K 305	720	138
75P	K-2N K 155	90	640	400	155	150	128	25	133,4	159	130	SCF K-2N K 155	510	143	DCF K-2N K 155	625	150
	K-2N K 195			440	195	190				199	134	SCF K-2N K 195	550	147	DCF K-2N K 195	665	154
	K-2N K 240			485	240	236				244	139	SCF K-2N K 240	595	152	DCF K-2N K 240	710	159
	K-2N K 270			515	270	265				274	141	SCF K-2N K 270	625	154	DCF K-2N K 270	740	161
	K-2N K 305			550	305	300				309	145	SCF K-2N K 305	660	158	DCF K-2N K 305	775	165
80P	K-2N K 195	125	810	421	195	190	160	28	166,4	193	190	SCF K-2N K 195	539	206	DCF K-2N K 195	639	218
	K-2N K 240			466	240	236				238	200	SCF K-2N K 240	584	216	DCF K-2N K 240	684	228
	K-2N K 270			496	270	265				268	208	SCF K-2N K 270	614	224	DCF K-2N K 270	714	236
	K-2N K 305			531	305	300				303	215	SCF K-2N K 305	649	231	DCF K-2N K 305	749	243
85P	K-2N K 195	125	810	495	195	190	160	28	166,4	193	260	SCF K-2N K 195	613	276	DCF K-2N K 195	713	288
	K-2N K 240			540	240	236				238	270	SCF K-2N K 240	658	286	DCF K-2N K 240	758	298
	K-2N K 270			570	270	265				268	278	SCF K-2N K 270	688	294	DCF K-2N K 270	788	306
	K-2N K 305			605	305	300				303	285	SCF K-2N K 305	723	301	DCF K-2N K 305	823	313
90P	K-2 K 240	135	1000	584	240	236	170	32	177,4	240	370	SCF K-2 K 240	604	410	DCF K-2 K 240	784	525
	K-2 K 270			614	270	265				270	380	SCF K-2 K 270	634	420	DCF K-2 K 270	814	535
	K-2 K 305			649	305	300				305	390	SCF K-2 K 305	669	430	DCF K-2 K 305	849	545
95P	K-2 K 240	135	1000	706	240	236	170	32	177,4	240	520	SCF K-2 K 240	826	560	DCF K-2 K 240	906	575
	K-2 K 270			736	270	265				270	530	SCF K-2 K 270	856	570	DCF K-2 K 270	936	585
	K-2 K 305			771	305	300				305	540	SCF K-2 K 305	891	580	DCF K-2 K 305	971	595

* Weight with oil

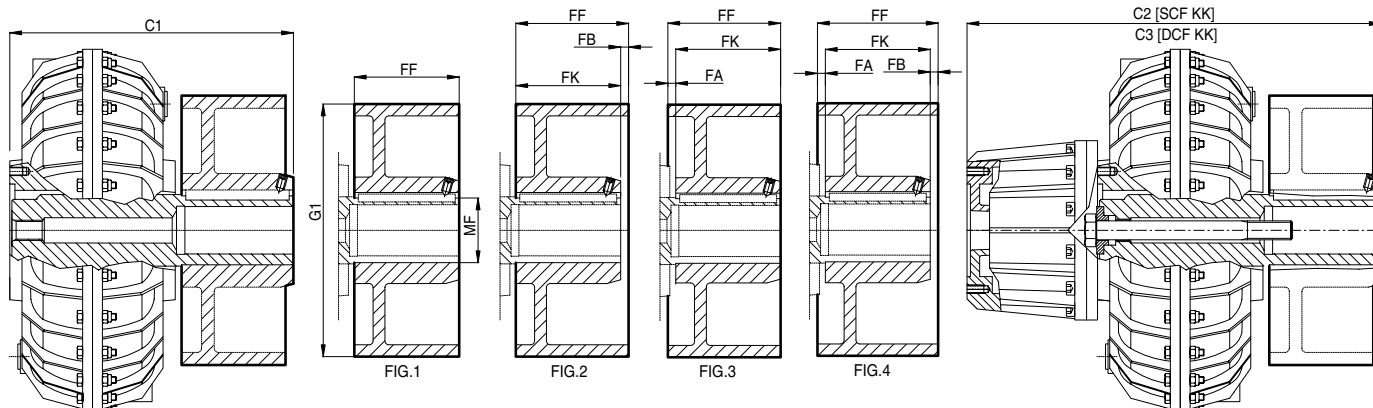

Coupling size 20-30-30P-40P-50-55-60-65

KK		SCF KK		DCF KK		Dimensions mm										Weight
Size	Type	C1	Type	C2	Type	C3	Drum "FP"	Fig.	G1	FF	MF _{H7}	FK	FA	FB	Kg.*	
20	K-2 K 70	185	-	-	-	-	FP-44-160	1	160	60	44	60	0	0	5	
	K-2 K 70	185	-	-	-	-	FP-44-200	4	200	75		60	14	1	7,5	
30	K-2 K 68	218	SCF K-2 K 68	273	DCF K-2 K 68	313	FP-57-160	1	160	60	57	60	0	0	6	
	K-2 K 88	238	SCF K-2 K 88	293	DCF K-2 K 88	333	FP-57-200		200	75		75	0	0	8	
	K-2 K 112	262	SCF K-2 K 112	317	DCF K-2 K 112	357	FP-57-250		250	95		95	0	0	14,5	
30P	K-2 K 68	218	SCF K-2 K 68	273	DCF K-2 K 68	313	FP-57-160	1	160	60	57	60	0	0	6	
	K-2 K 88	238	SCF K-2 K 88	293	DCF K-2 K 88	333	FP-57-200		200	75		75	0	0	8	
	K-2 K 112	262	SCF K-2 K 112	317	DCF K-2 K 112	357	FP-57-250		250	95		95	0	0	14,5	
40P	K-2 K 90	273	SCF K-2 K 90	331	DCF K-2 K 90	403	FP-77-200	1	200	75	77	75	0	0	9	
	K-2 K 90	273	SCF K-2 K 90	331	DCF K-2 K 90	403	FP-77-250	3	250	95		75	20	0	16	
	K-2 K 118	301	SCF K-2 K 118	359	DCF K-2 K 118	431	FP-77-315	3	315	118		115	3	0	28	
	K-2 K 118	301	SCF K-2 K 118	359	DCF K-2 K 118	431	FP-77-400	4	400	150		115	25	10	48	
50	K-2 K 90	234	SCF K-2 K 90	314	DCF K-2 K 90	389	FP-85-250	3	250	95	85	86	9	0	17	
	K-2 K 120	264	SCF K-2 K 120	344	DCF K-2 K 120	419	FP-85-315	1	315	118		118	0	0	28	
	K-2 K 155	299	SCF K-2 K 155	379	DCF K-2 K 155	454	FP-85-400	1	400	150		150	0	0	48	
55	K-2 K 90	286	SCFK-2 K 90	366	DCF K-2 K 90	441	FP-85-250	3	250	95	85	86	9	0	17	
	K-2 K 120	316	SCF K-2 K 120	396	DCF K-2 K 120	471	FP-85-315	1	315	118		118	0	0	28	
	K-2 K 155	351	SCF K-2 K 155	431	DCF K-2 K 155	506	FP-85-400	1	400	150		150	0	0	48	
60	K-2 K 130	302	SCF K-2 K 130	392	DCF K-2 K 130	472	FP-107-315	1	315	118	107	118	0	0	28	
	K-2 K 170	342	SCF K-2 K 170	432	DCF K-2 K 170	512	FP-107-400		400	150		150	0	0	50	
	K-2 K 230	402	SCF K-2 K 230	492	DCF K-2 K 230	572	FP-107-500		500	190		190	0	0	90	
65	K-2 K 130	350	SCF K-2 K 130	440	DCFK-2 K 130	520	FP-107-315	1	315	118	107	118	0	0	28	
	K-2 K 170	390	SCF K-2 K 170	480	DCF K-2 K 170	560	FP-107-400	1	400	150		150	0	0	50	
	K-2 K 220	440	SCF K-2 K 220	530	DCF K-2 K 220	610	FP-107-500	1	500	190		190	0	0	90	
	K-2 K 255	475	SCF K-2 K 255	565	DCF K-2 K 255	645	FP-107-630	1	630	236		236	0	0	151	
	K-2 K 255	475	SCF K-2 K 255	565	DCF K-2 K 255	645	FP-107-710	4	710	265		236	22	7	310	

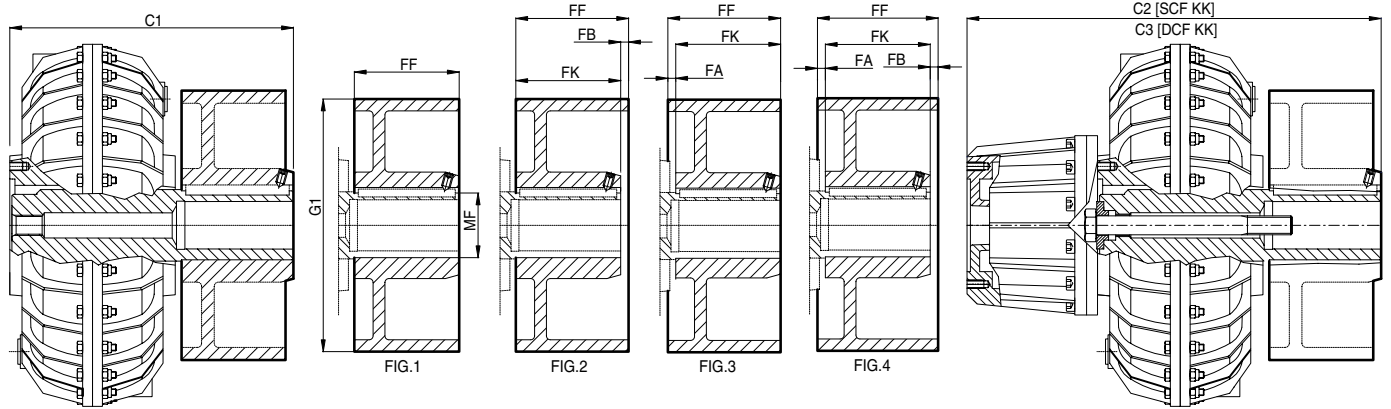

Coupling size 70P-75P-80P-85P-90P-95P

KK		SCF KK		DCF KK		Dimensions mm								Weight	
Size	Type	C1	Type	C2	Type	C3	Drum "FP"	Fig.	G1	FF	MF H7	FK	FA	FB	Kg.*
70P	K-2N K 155	345	SCF K-2N K 155	455	DCF K-2N K 155	570	FP-128-400	1	400	150	128	150	0	0	73
	K-2N K 195	385	SCF K-2N K 195	495	DCF K-2N K 195	610	FP-128-500		500	190		190	0	0	110
	K-2N K 240	430	SCF K-2N K 240	540	DCF K-2N K 240	655	FP-128-630		630	236		236	0	0	171
	K-2N K 270	460	SCF K-2N K 270	570	DCF K-2N K 270	685	FP-128-710		710	265		265	0	0	335
	K-2N K 305	495	SCF K-2N K 305	605	DCF K-2N K 305	720	FP-128-800		800	300		300	0	0	478
75P	K-2N K 155	400	SCF K-2N K 155	510	DCF K-2N K 155	625	FP-128-400	1	400	150	128	150	0	0	73
	K-2N K 195	440	SCF K-2N K 195	550	DCF K-2N K 195	665	FP-128-500		500	190		190	0	0	110
	K-2N K 240	485	SCF K-2N K 240	595	DCF K-2N K 240	710	FP-128-630		630	236		236	0	0	171
	K-2N K 270	515	SCF K-2N K 270	625	DCF K-2N K 270	740	FP-128-710		710	265		265	0	0	335
	K-2N K 305	550	SCF K-2N K 305	690	DCF K-2N K 305	775	FP-128-800		800	300		300	0	0	478
80P	K-2N K 195	421	SCF K-2N K 195	539	DCF K-2N K 195	639	FP-160-500	1	500	190	160	190	0	0	118
	K-2N K 240	466	SCF K-2N K 240	584	DCF K-2N K 240	684	FP-160-630		630	236		236	0	0	179
	K-2N K 270	496	SCF K-2N K 270	614	DCF K-2N K 270	714	FP-160-710		710	265		265	0	0	343
	K-2N K 305	531	SCF K-2N K 305	649	DCF K-2N K 305	749	FP-160-800		800	300		300	0	0	490
85P	K-2N K 195	495	SCF K-2N K 195	613	DCF K-2N K 195	713	FP-160-500	1	500	190	160	190	0	0	118
	K-2N K 240	540	SCF K-2N K 240	658	DCF K-2N K 240	758	FP-160-630		630	236		236	0	0	179
	K-2N K 270	570	SCF K-2N K 270	688	DCF K-2N K 270	788	FP-160-710		710	265		265	0	0	343
	K-2N K 305	605	SCF K-2N K 305	723	DCF K-2N K 305	823	FP-160-800		800	300		300	0	0	490
90P	K-2 K 240	584	SCF K-2 K 240	604	DCF K-2 K 240	784	FP-170-630	1	630	236	170	236	0	0	300
	K-2 K 270	614	SCF K-2 K 270	634	DCF K-2 K 270	814	FP-170-710		710	265		265	0	0	365
	K-2 K 305	649	SCF K-2 K 305	669	DCF K-2 K 305	849	FP-170-800		800	300		300	0	0	510
95P	K-2 K 240	706	SCF K-2 K 240	826	DCF K-2 K 240	906	FP-170-630	1	630	236	170	236	0	0	300
	K-2 K 270	736	SCF K-2 K 270	856	DCF K-2 K 270	936	FP-170-710		710	265		265	0	0	365
	K-2 K 305	771	SCF K-2 K 305	891	DCF K-2 K 305	971	FP-170-800		800	300		300	0	0	510

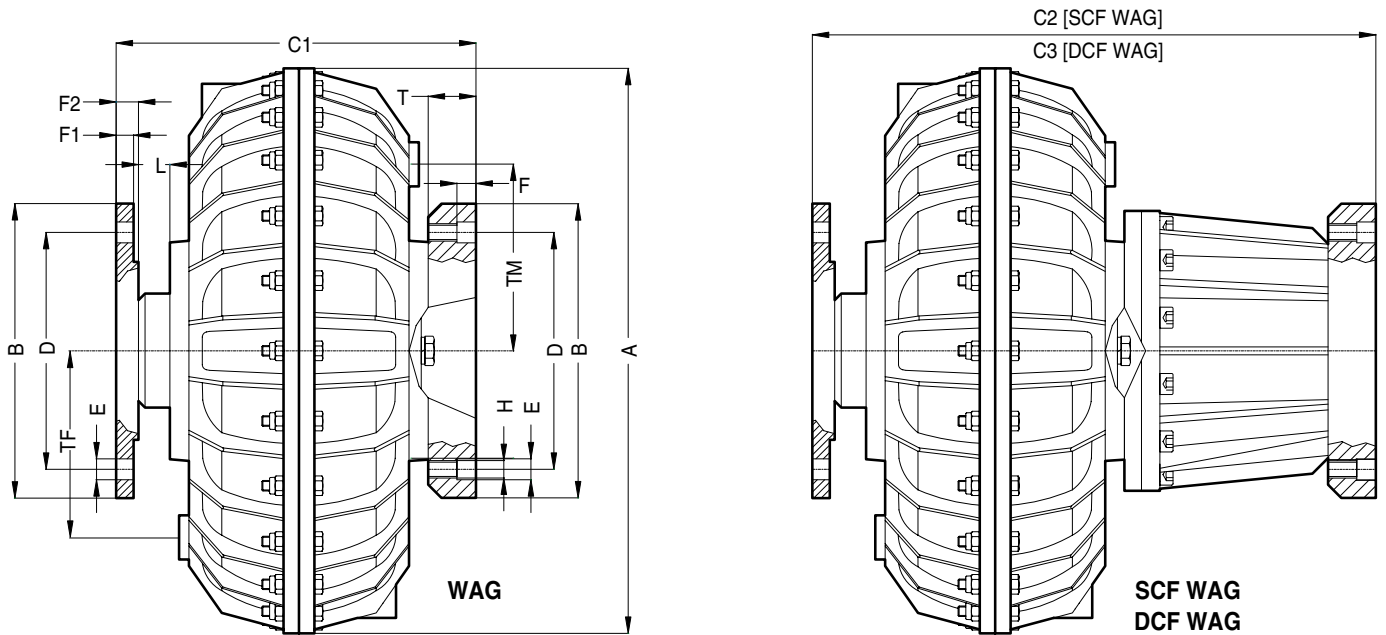

WAG																		
Size	Type	Basic Coupling	Dimensions mm														Gear Coupling	Weight Kg *
			A	B	C1	D	E		F	F1	F2	H	L	T	TF	TM		
							Nr	Ø										
20	WAG	K- Ø 28	230	116	150	95,25	6	6,4	7	6,5	8	¼ 28 UNF	10	17	75	80	1" S	8,5
30	WAG	K- Ø 38	290	152,5	192,5	122,22	8	9,57	7	6,5	12	⅜ 24 UNF	12	18,5	110	110	1" ½ S	18,3
30P	WAG	K- Ø 38	327		192,5								130		130	26,3		
40P	WAG	K- Ø 48	338		231								15		21	130		130
50	WAG	K- Ø 55	430	212	25	150	150	36,2										
55	WAG	K- Ø 60	430	253	15	24,5	150	150	54,3									
60	WAG	K- Ø 75	520	213	235	177,8	10	12,75	9,5	10	17,5	½ 20 UNF	20	25,5	205	192	2" ½ S	61
65	WAG	K- Ø 75	520	283	205	82,2												
70P	WAG	K- Ø 80	640	240	258,5	206,37	8	15,875	9,5	10	23	½ 20 UNF	20	25,5	265	265	3" E	102,7
75P	WAG	K- Ø 80	640	313,5	137,5													
80P	WAG	K- Ø 90	810	280	355	241,3	8	19,05	22	28	35	¾ 10 UNF	44	50	325	325	3" ½ E	202
85P	WAG	K- Ø 90	810	425	286													
90P	WAG	K- Ø 110	1000	318	456	279,4	8	19,05	22	28	42	¾ 10 UNF	20	50	416	416	4" E	450

SCF WAG						DCF WAG					
Size	Type	Basic Coupling	Dimensions mm		Weight Kg *	Size	Type	Basic Coupling	Dimensions mm		Weight Kg *
			Gear Coupling	C2					Gear Coupling	C3	
30	SCF WAG	K- Ø 38	1" ½ S	247,5	20,7	30	DCF WAG	K- Ø 38	1" ½ S	287,5	21,3
30P	SCF WAG	K- Ø 38		247,5	28,5	30P	DCF WAG	K- Ø 38		287,5	29,1
40P	SCF WAG	K- Ø 48		289	35,9	40P	DCF WAG	K- Ø 48		361	33,4
50	SCF WAG	K- Ø 55	2" ½ S	292	42	50	DCF WAG	K- Ø 55	2" ½ S	367	44,2
55	SCF WAG	K- Ø 60		333	60	55	DCF WAG	K- Ø 60		408	52,2
60	SCF WAG	K- Ø 75		325	69,4	60	DCF WAG	K- Ø 75		405	73
65	SCF WAG	K- Ø 75	3" E	373	90,6	65	DCF WAG	K- Ø 75	3" E	453	94,2
70P	SCF WAG	K- Ø 80		368,5	115,7	70P	DCF WAG	K- Ø 80		483,5	122,7
75P	SCF WAG	K- Ø 80		423,5	150,5	75P	DCF WAG	K- Ø 80		538,5	157,7
80P	SCF WAG	K- Ø 90	3" ½ E	473	218	80P	DCF WAG	K- Ø 90	3" ½ E	573	232
85P	SCF WAG	K- Ø 90		543	302	85P	DCF WAG	K- Ø 90		643	314
90P	SCF WAG	K- Ø 110		576	490	90P	DCF WAG	K- Ø 110		656	505

* Weight with oil

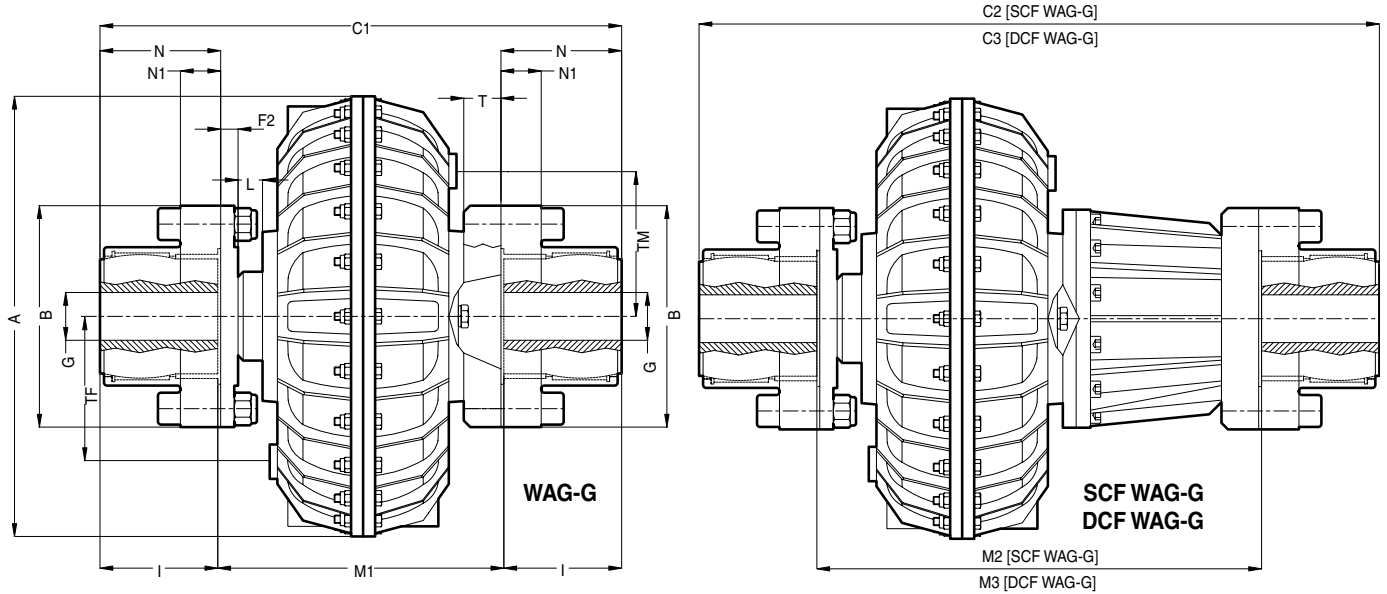

NOTE: For bore and keyway dimensions see sheet 10-023A

WAG-G																		
Size	Type	Basic Coupling	Dimensions mm														Weight Kg. *	
			A	B	C1	G		F2	I	L	M1	N	N1	T	TF	TM		Gear Coupling
20	WAG-G	K1-Ø 28	230	111	240	raw	max	8	43	10	154	44,5	12	18	80	80	RE 40	13
30	WAG-G	K1-Ø 38	290	142	297	15	60	12	50	12	197	51,5	10	20	110	110	RE 55	26,3
30P	WAG-G	K1-Ø 38	327		297						197				130	130		34,1
40P	WAG-G	K1-Ø 48	338		334						234				130	130		36,2
50	WAG-G	K2-Ø 55	430	200	315	35	95	17,5	76	25	215	78,5	13	24,5	150	150	RE 85	44,2
55	WAG-G	K2-Ø 60	430		410						258				150	150		79,3
60	WAG-G	K2-Ø 75	520		392						240				192	110		86
65	WAG-G	K2-Ø 75	520	440	288	205	205	107,2										
70P	WAG-G	K2-Ø 80	640	225	448,5	45	110	23	90	20	268,5	92,5	13	30,5	265	265	RE 100	146,7
75P	WAG-G	K2-Ø 80	640		503,5						323,5							187,5
80P	WAG-G	K2-Ø 90	810	265	548	55	130	28	105	44	338	108	22	34	325	325	RE 120	262
85P	WAG-G	K2-Ø 90	810		618						408							346
90P	WAG-G	K2-Ø 110	1000	370	748	90	190	42	150	20	448	154	24	34	416	416	RE 180	550
95P	WAG-G	K2-Ø 110	1000		863						563							710
1200	WAG-G	K2-Ø 160	1300	ON REQUEST														

SCF WAG-G							DCF WAG-G						
Size	Type	Basic Coupling	Dimensions mm			Weight Kg. *	Size	Type	Basic Coupling	Dimensions mm			Weight Kg. *
			Gear Coupling	C2	M2					Gear Coupling	C3	M3	
30	SCF WAG-G	K1-Ø 38	RE 55	352	252	28,7	30	DCF WAG-G	K1-Ø 38	RE 55	392	292	29,3
30P	SCF WAG-G	K1-Ø 38		352	252	36,5	30P	DCF WAG-G	K1-Ø 38		392	292	37,1
40P	SCF WAG-G	K1-Ø 48		392	292	39,9	40P	DCF WAG-G	K1-Ø 48		464	364	41,2
50	SCF WAG-G	K2-Ø 55	RE 85	395	295	50	50	DCF WAG-G	K2-Ø 55	RE 85	470	370	52,2
55	SCF WAG-G	K2-Ø 60		490	338	85,1	55	DCF WAG-G	K2-Ø 60		565	413	87,2
60	SCF WAG-G	K2-Ø 75		482	330	94,4	60	DCF WAG-G	K2-Ø 75		562	410	98
65	SCF WAG-G	K2-Ø 75	530	378	115,6	65	DCF WAG-G	K2-Ø 75	610	458	119,2		
70P	SCF WAG-G	K2-Ø 80	RE 100	558,5	378,5	159,7	70P	DCF WAG-G	K2-Ø 80	RE 100	673,5	493,5	166,7
75P	SCF WAG-G	K2-Ø 80		613,5	433,5	200,5	75P	DCF WAG-G	K2-Ø 80		728,5	548,5	207,5
80P	SCF WAG-G	K2-Ø 90	RE 120	666	456	278	80P	DCF WAG-G	K2-Ø 90	RE 120	766	556	290
85P	SCF WAG-G	K2-Ø 90		736	526	382	85P	DCF WAG-G	K2-Ø 90		836	626	374
90P	SCF WAG-G	K2-Ø 110	RE 180	868	568	590	90P	DCF WAG-G	K2-Ø 110	RE 180	949	648	605
95P	SCF WAG-G	K2-Ø 110		983	683	750	95P	DCF WAG-G	K2-Ø 110		1063	763	765

* Weight with oil

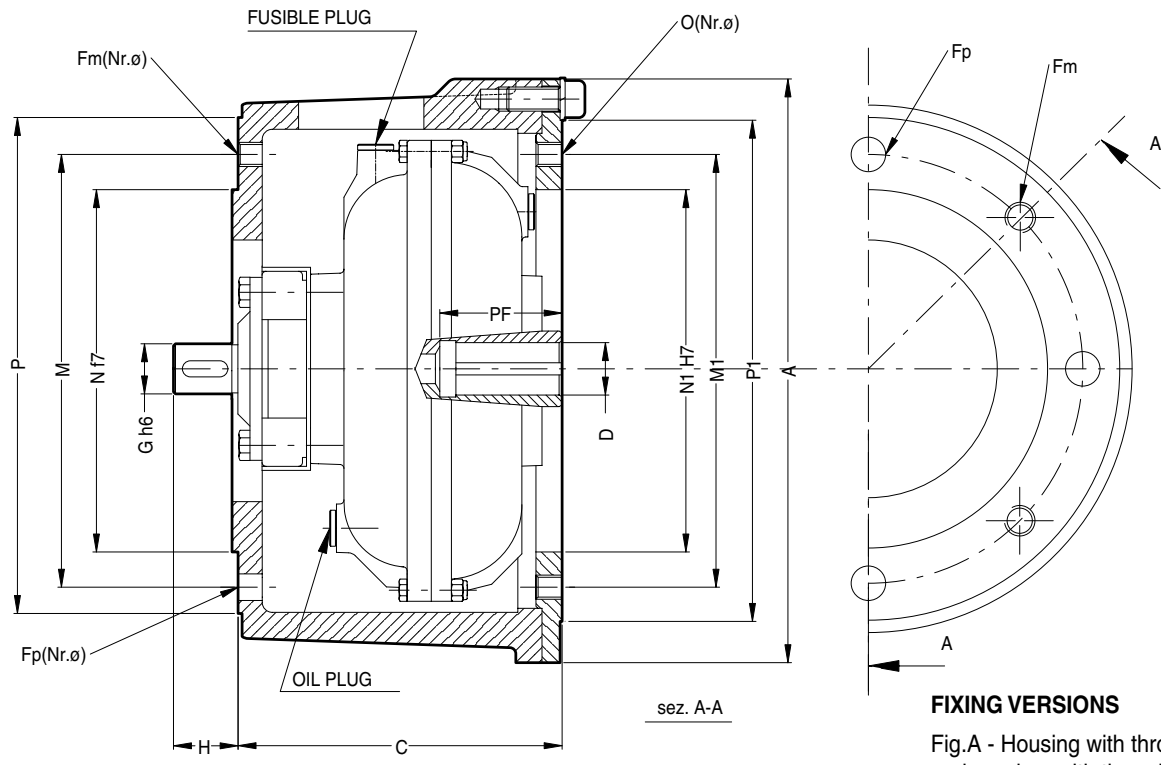

FIXING VERSIONS

- Fig.A - Housing with through holes and gearbox with threaded holes
- Fig.B - Housing with through holes and gearbox with through holes
- Fig.C - Housing with threaded holes and gearbox with through holes

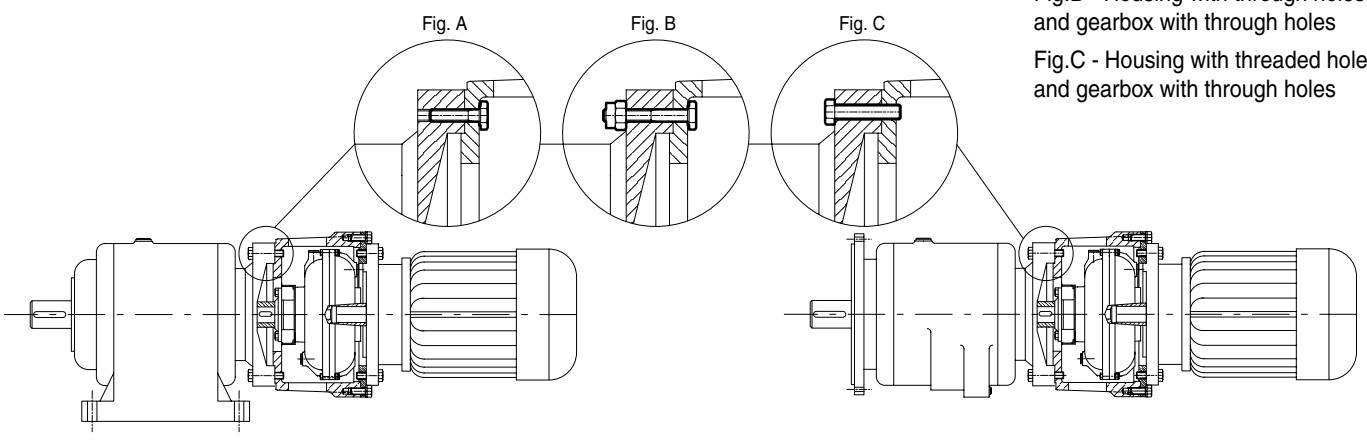

Feet mounted Gearbox

Flange mounted Gearbox

Coupling		Motor		Dimensions mm.														Weight		
Size	Type	Type	KW	A	C	D	Fm	Fp	G	H	M	M1	N (f7)	N1 (H7)	O	P	P1	PF	Kg.*	
10CK	19LRS19	80	0,55	240	128	19	Nr.4 M10	Nr.4 ø11	19	25	165	165	130	130	Nr.8 M10	200	200	45	8,5	
			0,75																	
10CK	24LRS24	90 S	1,1	240	128	24	Nr.4 M10	Nr.4 ø11	24	25	165	165	130	130	Nr.8 M10	200	200	55	8,5	
			90 L																	1,5
			100																	2,2
20CK	28LRS28	100	3	292	161	28	Nr.4 M12	Nr.4 ø13	28	32	215	215	180	180	Nr.8 M12	250	250	65	24	
			100																	4
			112 M																	
30CK	38LRS38	132 L	9,2	350	210	38	Nr.4 M12	Nr.4 ø13	38	45	265	265	230	230	Nr.8 M12	300	300	82	36,5	
30PCK	42LRS42	160 M	11	400	210	42	Nr.4 M16	Nr.4 ø17	42	45	300	300	250	250	Nr.8 M16	350	350	112	40	
			160 L																	15
40PCK	48LRS48	180 M	18,5	400	255	48	Nr.4 M16	Nr.4 Ø17	48	55	300	300	350	250	Nr.8 M16	350	350	112	42	
			180 L																	22

* Weight with oil

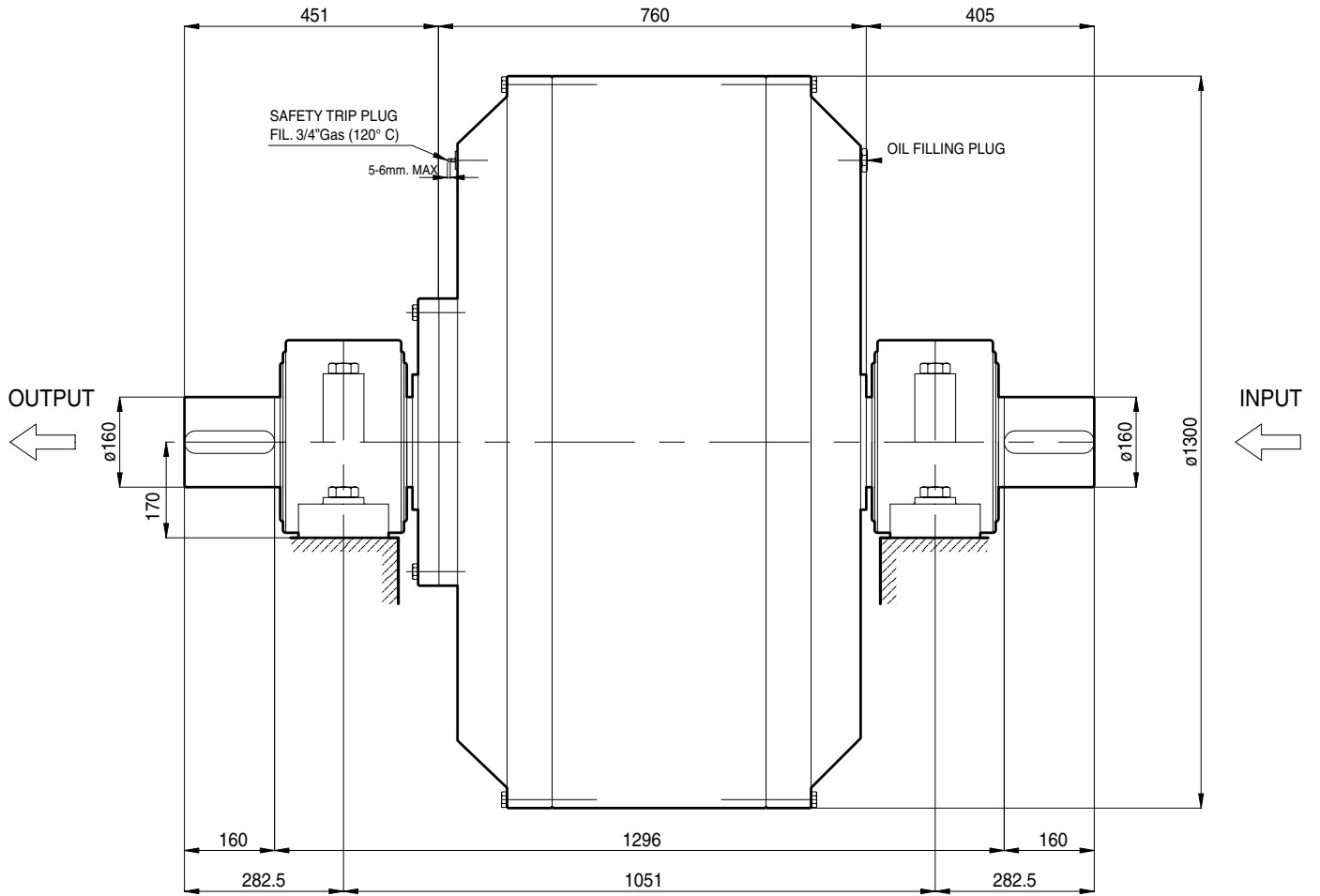

Specify installation required "STANDARD ASSEMBLY" or "REVERSE ASSEMBLY"
see page 12

WEIGHT Kg. Without oil	OIL CAPACITY max. lt.	OIL DENSITY	WEIGHT Kg. max. with oil
2400	400	0,88	2752

THE DELAY FILL CHAMBERS "SCF AND DCF" CAN BE ALSO FITTED TO THE VERSIONS "J"- "H"- "Z"

ROTOFLUID BETA X for pulley with bearing support under the belts tension.

**BUILT-IN PULLEY
TYPE X-XC-XM-XN**

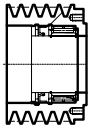

**DEMOUNTABLE PULLEY
TYPE XJ-NJ**

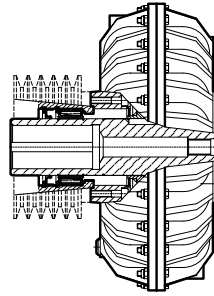
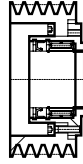

page 36/37

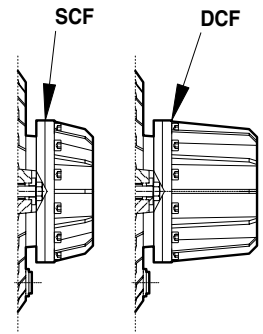

ROTOFLUID BETA J with bearing supported output sleeve for externally bolted v-belt pulley J-JA-JG

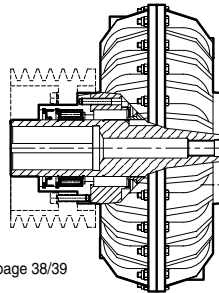

page 38/39

ROTOFLUID BETA H with bearing supported output sleeve keyed v-belt pulley "P"

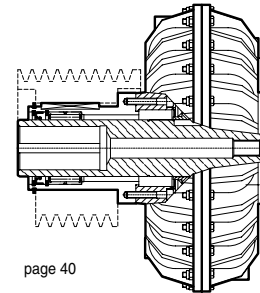

page 40

ROTOFLUID BETA Z

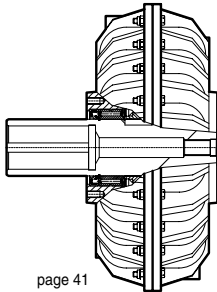

page 41

ROTOFLUID BETA Z for externally bolted demountable pulley F-T-FT-TG-TM-TR

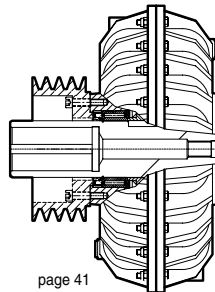

page 41

ROTOFLUID BETA ZI for externally bolted built-in pulley I-IF-IG

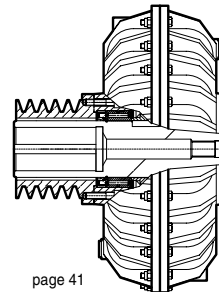

page 41

SPECIAL VERSIONS

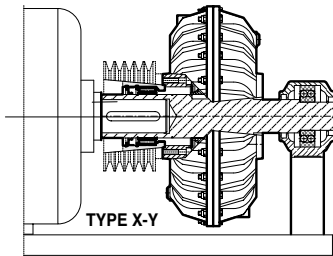

TYPE X-Y

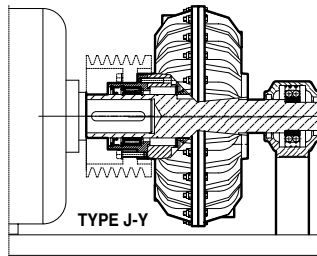

TYPE J-Y

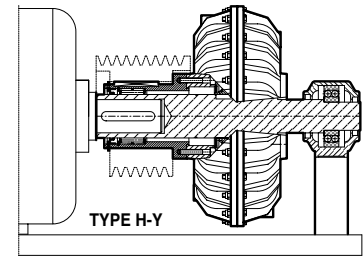

TYPE H-Y

ROTOFLUID ALFA
in-line version for pulley

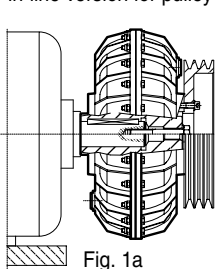

Fig. 1a

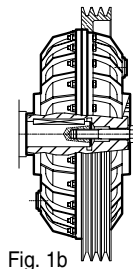

Fig. 1b

ROTOFLUID ALFA
in-line for pulley with support

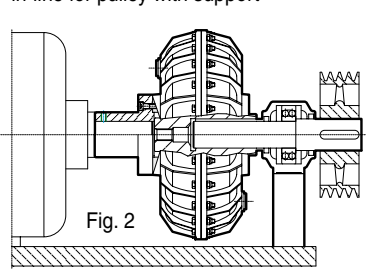

Fig. 2

ROTOFLUID ALFA
in-line version for pulley with double support

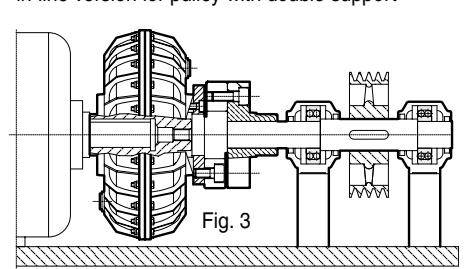

Fig. 3

Fig. 1-2 HORIZONTAL SHAFT

Fig. 3-4 VERTICAL SHAFT

In case of order specify mounting figure (if different from STANDARD)

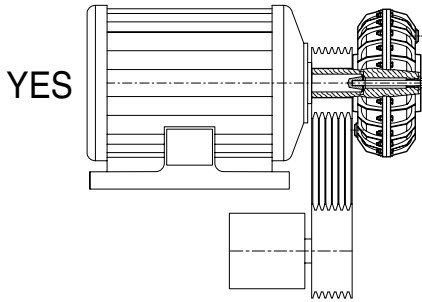

Fig. 1
STANDARD

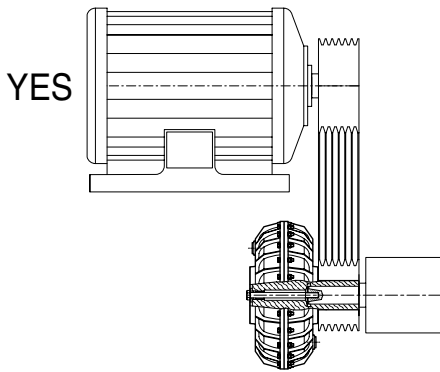
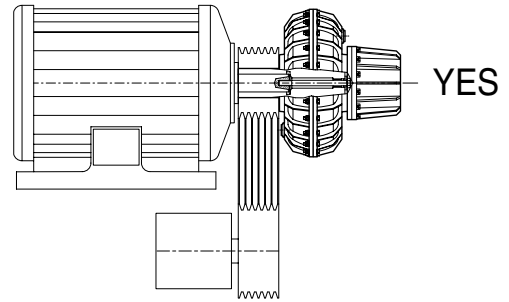

Fig. 2

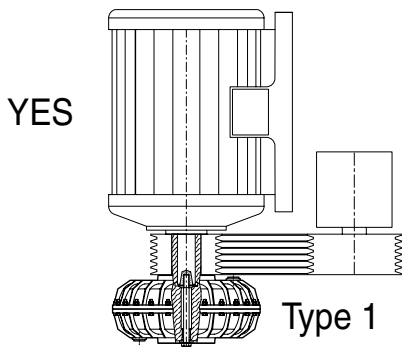
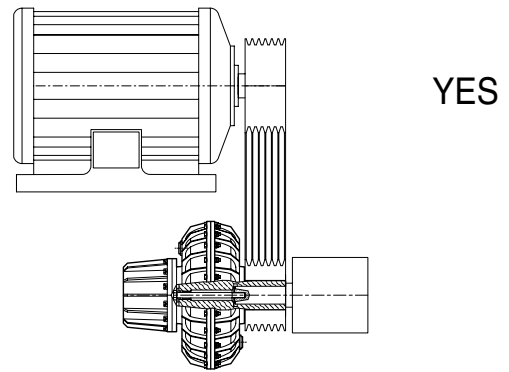

Fig. 3

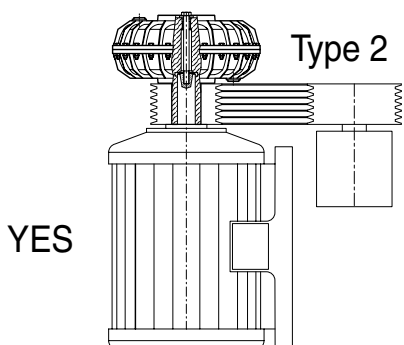
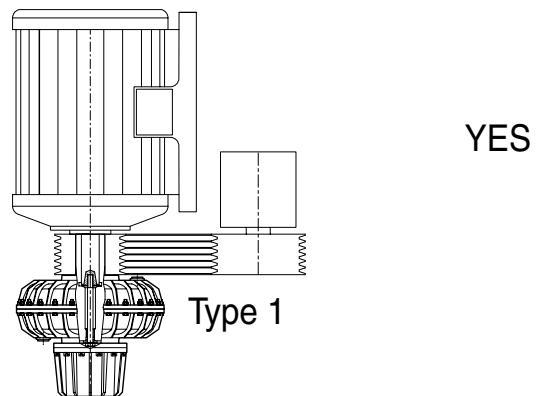
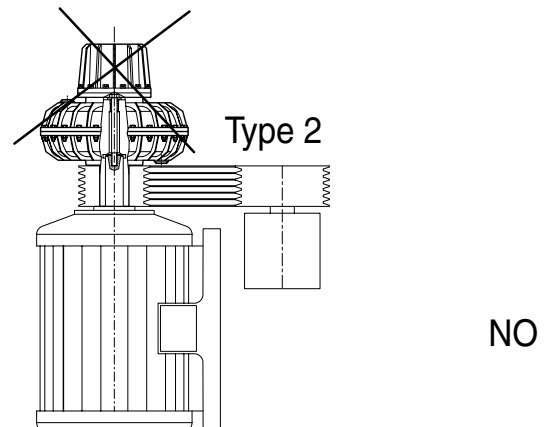
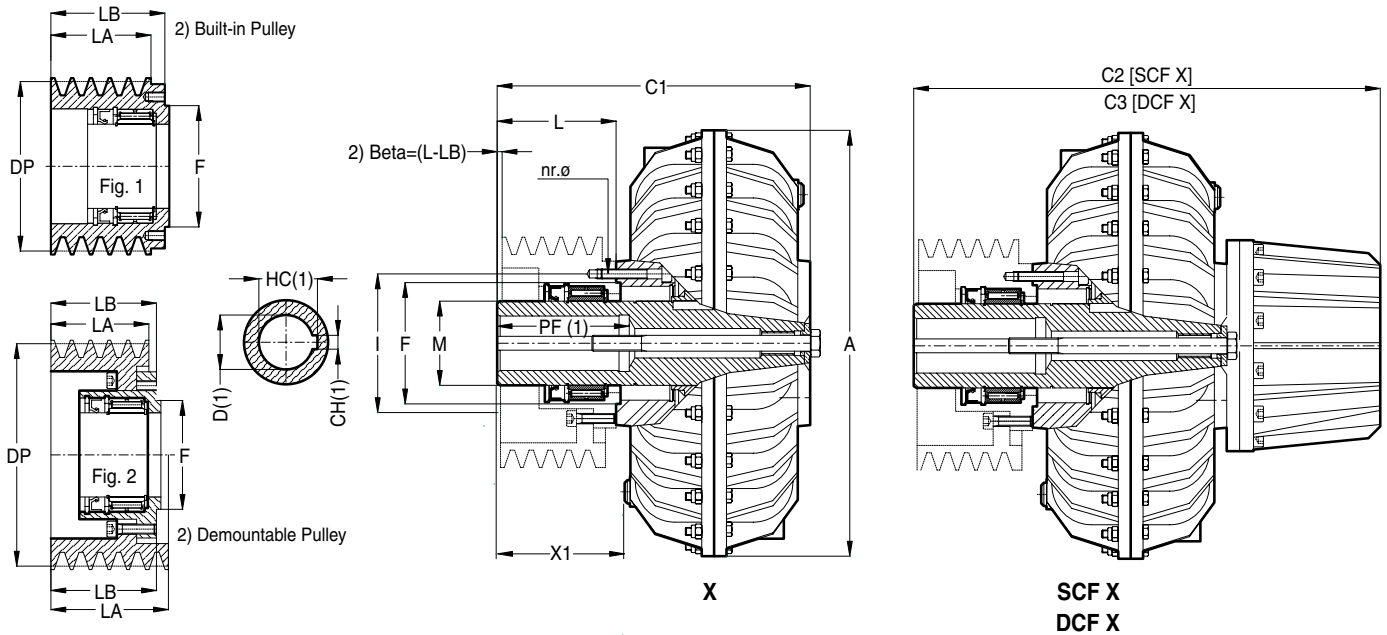

Fig. 4





NOTE: 1) FOR BORE AND KEYWAY DIMENSIONS SEE SHEET. 10-019D

2) FOR THE CHOICE OF THE ASSEMBLING COUPLING-PULLEY, SEE "WESTCAR PULLEYS" CATALOGUE

Size	X											SCF X			DCF X			
	Dimensions mm.										Weight	Dimensions mm.		Weight	Dimensions mm.		Weight	
	Type	D	A	C1	F	I	L	M	nr-ø	X1	Kg.*	Type	C2	Kg.*	Type	C3	Kg.*	
20	X 103	38-42	230	218	62	78	103	55	6-M6	120	7	-	-	-	-	-	-	
30	X 68	28-38-42	290	218	75	100	68	60	8-M8	77	14	SCF X 68	273	16,4	DCF X 68	313	17	
	X 80	48-55		230			80	70		89	14,5	SCF X 80	285	16,9	DCF X 80	325	17,5	
	X 88	28-38-42		238			88	60		97	14,8	SCF X 88	293	17,2	DCF X 88	333	17,8	
	X 112	28-38-42		262			112	60		121	15,5	SCF X 112	317	17,9	DCF X 112	357	18,5	
	X 114	48		264			114	65		123	15,5	SCF X 114	319	17,9	DCF X 114	359	18,5	
	X 135	42-48-55	285	135	70	144	16	SCF X 135	340	18,4	DCF X 135	380	19					
30P	X 68	28-38-42	327	218	75	100	68	60	8-M8	72	22	SCF X 68	273	24,4	DCF X 68	313	25	
	X 80	48-55		230			80	70		84	22,5	SCF X 80	285	24,9	DCF X 80	325	25,5	
	X 88	28-38-42		238			88	60		92	22,8	SCF X 88	293	25,2	DCF X 88	333	25,8	
	X 112	28-38-42		262			112	60		116	23,5	SCF X 112	317	25,9	DCF X 112	357	26,5	
	X 114	48		264			114	65		118	23,5	SCF X 114	319	25,9	DCF X 114	359	26,5	
	X 135	42-48-55	285	135	70	139	24	SCF X 135	340	26,4	DCF X 135	380	27					
40P	X 64	42-48	338	247	100	125	64	80	8-M8	88	23	SCF X 64	305	26,7	DCF X 64	377	28,2	
	X 90	38-42-48-55-60		273			90			114	25	SCF X 90	331	28,7	DCF X 90	403	30,2	
	X 118	38-42-48-55-60		301			118			142	27	SCF X 118	359	30,7	DCF X 118	431	32,2	
	X 142	38-42-48-55-60		325			142			166	30	SCF X 142	383	33,7	DCF X 142	455	35,2	
	X N64	42-48		247			145			97	88	28	SCF X N64	305	31,7	DCF X N64	377	33,2
	X N90	38-42-48-55-60		273			145			123	114	30	SCF X N90	331	33,7	DCF X N90	403	35,2
	X N118	38-42-48-55-60		301			145			151	142	32	SCF X N118	359	35,7	DCF X N118	431	37,2
	X N142	38-42-48-55-60	325	145	175	166	35	SCF X N142	383	38,7	DCF X N142	455	40,2					
50	X 90	42-48-55-60-65	430	244	110	140	90	85	8-M10	96	32,5	SCF X 90	324	38,3	DCF X 90	399	40,5	
	X 120			274			120			126	33,5	SCF X 120	354	39,3	DCF X 120	429	41,5	
	X 155			309			155			161	34,5	SCF X 155	389	40,3	DCF X 155	464	42,5	
	X 180			334			180			186	35,5	SCF X 180	414	41,3	DCF X 180	489	43,5	
55	X 90	42-48-55-60-65	430	286	110	140	90	85	8-M10	96	41	SCF X 90	366	46,8	DCF X 90	441	49	
	X 120	42-48-55-60-65		316			120			85	126	42	SCF X 120	396	47,8	DCF X 120	471	50
	X 155	42-48-55-60-65		351			155			85	161	43	SCF X 155	431	48,8	DCF X 155	506	51
	X 160	75		356			160			105	166	43	SCF X 160	436	48,8	DCF X 160	511	51
	X 200	42-48-55-60-65		396			200			85	206	44	SCF X 200	476	49,8	DCF X 200	551	52
	X 230	75		426			230			105	236	46	SCF X 230	506	51,8	DCF X 230	581	54

* Weight with oil - Standard bores in heavy type

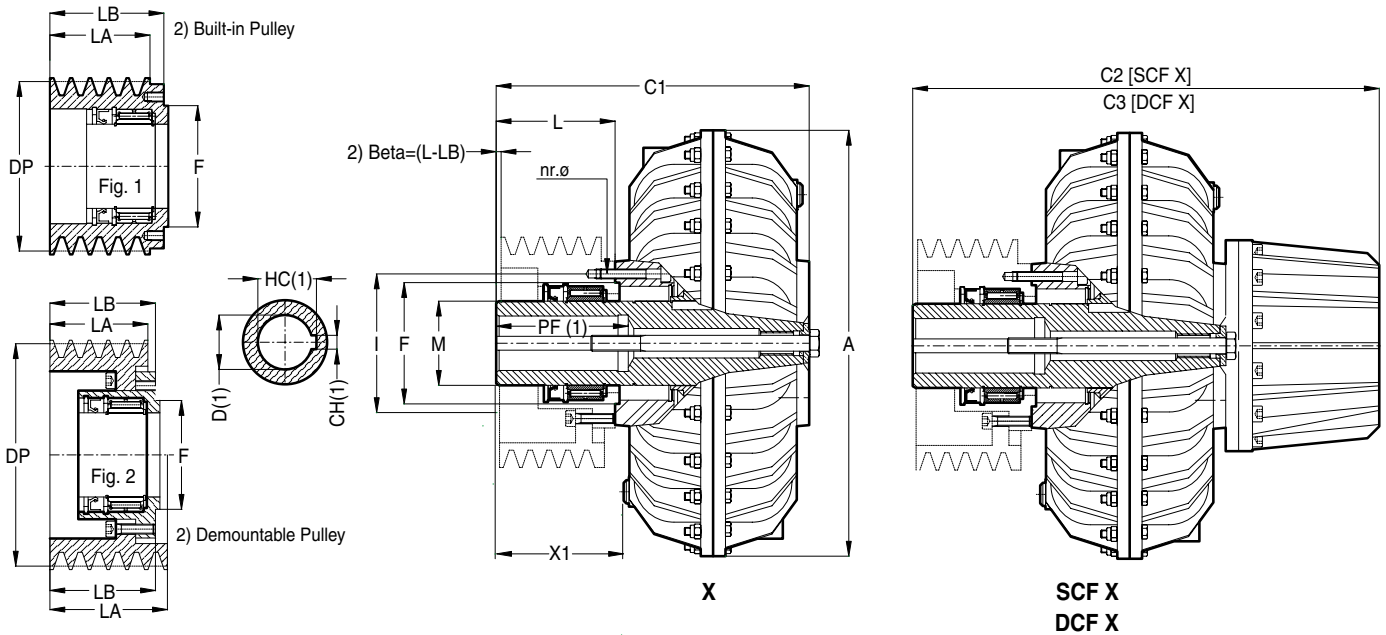

NOTE: 1) FOR BORE AND KEYWAY DIMENSIONS SEE SHEET. 10-019D

2) FOR THE CHOICE OF THE ASSEMBLING COUPLING-PULLEY, SEE "WESTCAR PULLEYS" CATALOGUE

Size	X											SCF X			DCF X		
	Dimensions mm.										Weight	Dimensions mm.		Weight	Dimensions mm.		Weight
	Type	D	A	C1	F	I	L	M	nr-Ø	X1	Kg.*	Type	C2	Kg.*	Type	C3	Kg.*
60	X 130	55-60-65-75-80	520	302	125	160	130	110	8-M10	136	50	SCF X 130	392	58,4	DCF X 130	472	62
	X 170			342			170			176	53	SCF X 170	432	61,4	DCF X 170	512	65
	X 178			350			178			184	53	SCF X 178	440	61,4	DCF X 178	520	65
	X 218			390			218			224	55	SCF X 218	480	63,4	DCF X 218	560	67
	X 230			402			230			236	56	SCF X 230	492	64,4	DCF X 230	572	68
65	X 130	60-65-75-80	520	350	125	160	130	110	8-M10	136	69	SCF X 130	440	77,4	DCF X 130	520	81
	X 170			390			170			176	72	SCF X 170	480	80,4	DCF X 170	560	83
	X 220			440			220			226	76	SCF X 220	530	84,4	DCF X 220	610	88
	X 255			475			255			261	79	SCF X 255	565	87,4	DCF X 255	645	91
70P	X 170	75-80-90-100	640	380	150	195	170	• 120	8-M12	170	111	SCF X 170	490	118	DCF X 170	605	125
	X 210			420			210			210	114	SCF X 210	530	121	DCF X 210	645	128
	X 230			440			230			230	117	SCF X 230	550	124	DCF X 230	665	131
	X 275			485			275			275	121	SCF X 275	595	128	DCF X 275	710	135
75P	X 160	80-90-100	640	420	150	195	160	• 120	8-M12	160	142	SCF X 160	530	143	DCF X 160	645	150
	X 210			470			210			210	147	SCF X 210	580	148	DCF X 210	695	155
	X 230			490			230			230	153	SCF X 230	600	154	DCF X 230	715	161
	X 275			535			275			275	158	SCF X 275	645	159	DCF X 275	760	166
80P	X 160A	Ø max. 100	810	386	190	230	160	140	8-M14	160	192	SCF X 160A	504	201	DCF X 160A	604	213
	X 210A	Ø max. 100		436			210	140	8-M14	210	202	SCF X 210A	554	211	DCF X 210A	654	223
	X 255A	Ø max. 100		481			255	140	8-M14	255	207	SCF X 255A	599	216	DCF X 255A	699	228
	X 255B	Ø max. 125		481			255	160	8-M16	255	215	SCF X 255B	599	224	DCF X 255B	699	236
85P	X 160A	Ø max. 100	810	460	190	230	160	140	8-M14	160	270	SCF X 160A	578	279	DCF X 160A	678	291
	X 230A	Ø max. 100		530			230	140	8-M14	230	280	SCF X 230A	648	289	DCF X 230A	748	301
	X 255A	Ø max. 100		555			255	140	8-M14	255	290	SCF X 255A	673	299	DCF X 255A	773	311
	X 255B	Ø max. 125		555			255	160	8-M16	255	298	SCF X 255B	673	307	DCF X 255B	773	319

*Weight with oil - • PER D=100 - M=135 - Standard bores in heavy type

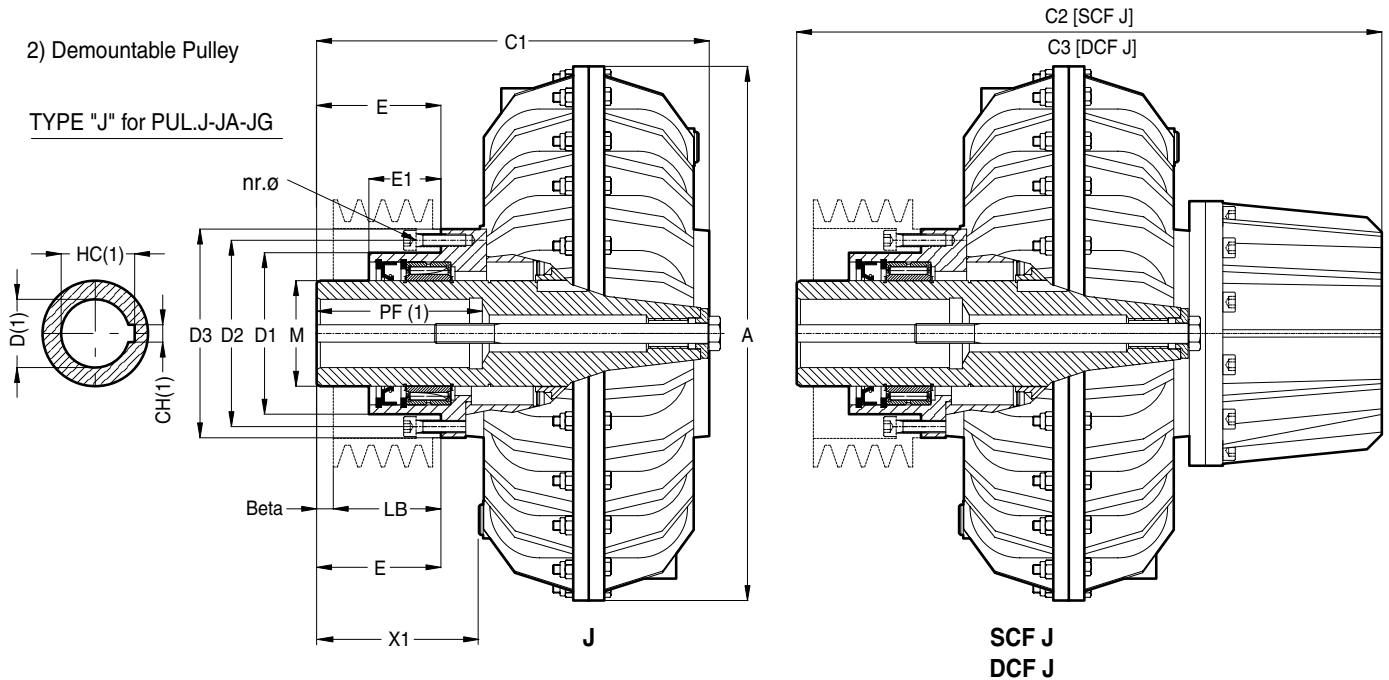

NOTE : 1) FOR BORE AND KEYWAY DIMENSIONS SEE SHEET. 10-019D

2) FOR THE CHOICE OF THE ASSEMBLING COUPLING-PULLEY, SEE "WESTCAR PULLEYS" CATALOGUE

Size	J												SCF J			DCF J				
	Dimensions mm.											Weight	Dimensions mm.		Weight	Dimensions mm.		Weight		
	Type	D	A	C1	D1 H7	D2	D3	E	E1	M	nr.-Ø	X1	Kg *	Type	C2	Kg *	Type	C3	Kg *	
20	J 70	19-24-28	229	185	60	75	92	70	12	45	6-M8	77	6,5	-	-	-	-	-	-	
	J 103	28-38		218	75	90	104	85	32	55		120	9	-	-	-	-	-	-	-
30	J 68	28-38-42	290	218	85	100	114	50	45	60	8-M8	77	15	SCF J 68	273	17,4	DCF J 68	313	18	
	J 80	48-55		230	96	110	124	62				70	89	16	SCF J 80	285	18,4	DCF J 80	325	19
	J 88	28-38-42		238	85	100	114	70				60	97	16	SCF J 88	293	18,4	DCF J 88	333	19
	J 112	28-38-42		262	85	100	114	94				60	121	19	SCF J 112	317	21,4	DCF J 112	357	22
	J 135	42-48-55		285	96	110	124	117				70	144	20	SCF J 135	340	22,4	DCF J 135	380	23
30P	J 68	28-38-42	327	218	85	100	114	50	45	60	8-M8	72	23	SCF J 68	273	25,4	DCF J 68	313	26	
	J 80	48-55		230	96	110	124	62				70	84	24	SCF J 80	285	26,4	DCF J 80	325	27
	J 88	28-38-42		238	85	100	114	70				60	92	24	SCF J 88	293	26,4	DCF J 88	333	27
	J 112	28-38-42		262	85	100	114	94				60	116	27	SCF J 112	317	29,4	DCF J 112	357	30
	J 135	42-48-55		285	96	110	124	117				70	139	28	SCF J 135	340	30,4	DCF J 135	380	31
40P	J 64	42-48	338	247	112	130	145	63	60	80	8-M8	88	24	SCF J 64	305	28	DCF J 64	377	29	
	J 90	38-42-48-55-60		273				89				114	26	SCF J 90	331	30	DCF J 90	403	31	
	J 118	38-42-48-55-60		301				117				142	29	SCF J 118	359	33	DCF J 118	431	34	
	J 142	38-42-48-55-60		325				141				166	31	SCF J 142	383	35	DCF J 142	455	36	
50	J 90	42-48-55-60-65	430	244	130	150	170	70	58	85	8-M10	96	40	SCF J 90	324	46	DCF J 90	399	48	
	J 120			274				100				126	41	SCF J 120	354	47	DCF J 120	429	49	
	J 155			309				135				161	42	SCF J 155	389	48	DCF J 155	464	50	
	J 180			334				160				186	45	SCF J 180	414	51	DCF J 180	489	53	
55	J 90	42-48-55-60-65	430	286	130	150	170	70	58	85	8-M10	96	48	SCF J 90	366	54	DCF J 90	441	56	
	J 120			316				100				126	50	SCF J 120	396	56	DCF J 120	471	58	
	J 155			351				135				161	52	SCF J 155	431	58	DCF J 155	506	60	
	J 200			396				180				206	55	SCF J 200	476	61	DCF J 200	551	63	

* Weight with oil - Standard bores in heavy type

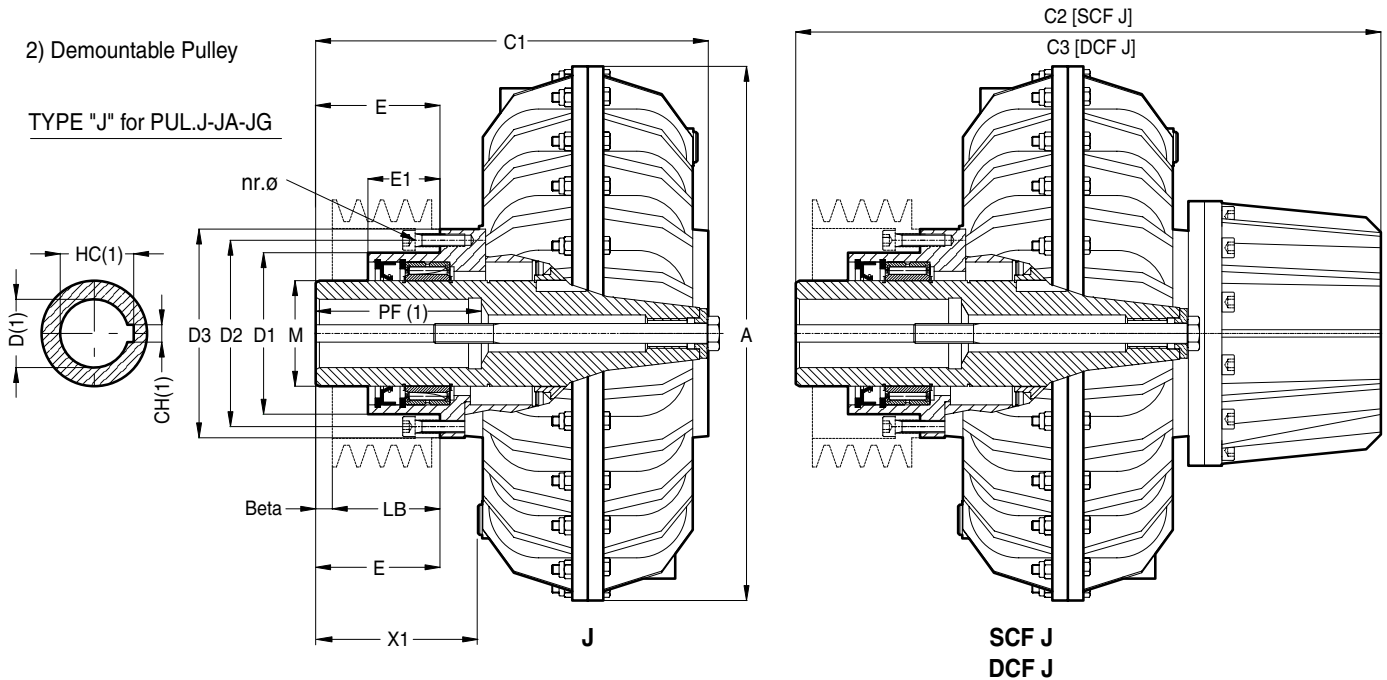

NOTE: 1) FOR BORE AND KEYWAY DIMENSIONS SEE SHEET. 10-019D
2) FOR THE CHOICE OF THE ASSEMBLING COUPLING-PULLEY, SEE "WESTCAR PULLEYS" CATALOGUE

Size	J												SCF J			DCF J			
	Dimensions mm.												Weight	Dimensions mm.		Weight	Dimensions mm.		Weight
	Type	D	A	C1	D1 H7	D2	D3	E	E1	M	nr.-Ø	X1	Kg *	Type	C2	Kg *	Type	C3	Kg *
60	J 130	55-60-65-75-80	520	302	150	170	186	110	88	110	8-M10	136	65	SCF J 130	392	74	DCF J 130	472	77
	J 170			342				150				176	70	SCF J 170	432	79	DCF J 170	512	82
	J 178			350				158				184	71	SCF J 178	440	80	DCF J 178	520	83
	J 218			390				198				224	76	SCF J 218	480	85	DCF J 218	560	88
	J 230			402				210				236	80	SCF J 230	492	89	DCF J 230	572	92
65	J 130	55-60-65-75-80	520	350	150	170	186	110	88	110	8-M10	136	83	SCF J 130	440	92	DCF J 130	520	95
	J 170			390				150				176	88	SCF J 170	480	97	DCF J 170	560	100
	J 220			440				200				226	94	SCF J 220	530	103	DCF J 220	610	106
	J 255			475				235				261	100	SCF J 255	565	109	DCF J 255	645	112
70P	J 170	75-80-90-100	640	380	188	210	230	140	100	120	8-M12	170	115	SCF J 170	490	128	DCF J 170	605	135
	J 210			420				170				210	118	SCF J 210	530	131	DCF J 210	645	138
	J 230			440				200				230	121	SCF J 230	550	134	DCF J 230	665	141
	J 275			485				245				275	125	SCF J 275	595	138	DCF J 275	710	145
75P	J 160	80-90-100	640	420	188	210	230	130	100	120	8-M12	160	150	SCF J 160	530	163	DCF J 160	645	170
	J 210			470				180				210	153	SCF J 210	580	166	DCF J 210	695	173
	J 230			490				200				230	154	SCF J 230	600	167	DCF J 230	715	174
	J 275			535				245				275	160	SCF J 275	645	173	DCF J 275	760	180
80P	J 160A	Ø max. 100	810	386	214	240	270	130	130	140	8-M14	160	185	SCF J 160A	504	201	DCF J 160A	604	213
	J 210A	Ø max. 100		436	214	240	270	180	130	140	8-M14	210	195	SCF J 210A	554	211	DCF J 210A	654	223
	J 255A	Ø max. 100		481	214	240	270	225	130	140	8-M14	255	200	SCF J 255A	599	216	DCF J 255A	699	228
	J 255B	Ø max. 125		481	225	250	276	143	43	160	8-M16	255	208	SCF J 255B	599	224	DCF J 255B	699	236
85P	J 160A	Ø max. 100	810	460	214	240	270	130	130	140	8-M14	160	250	SCF J 160A	578	266	DCF J 160A	678	178
	J 230A	Ø max. 100		530	214	240	270	200	130	140	8-M14	230	260	SCF J 230A	648	276	DCF J 230A	748	288
	J 255A	Ø max. 100		555	214	240	270	225	130	140	8-M14	255	270	SCF J 255A	673	286	DCF J 255A	773	298
	J 255B	Ø max. 125		555	225	250	276	143	43	160	8-M16	255	278	SCF J 255B	673	294	DCF J 255B	773	306

*Weight with oil - • PER D=100 - M=135 - Standard bores in heavy type

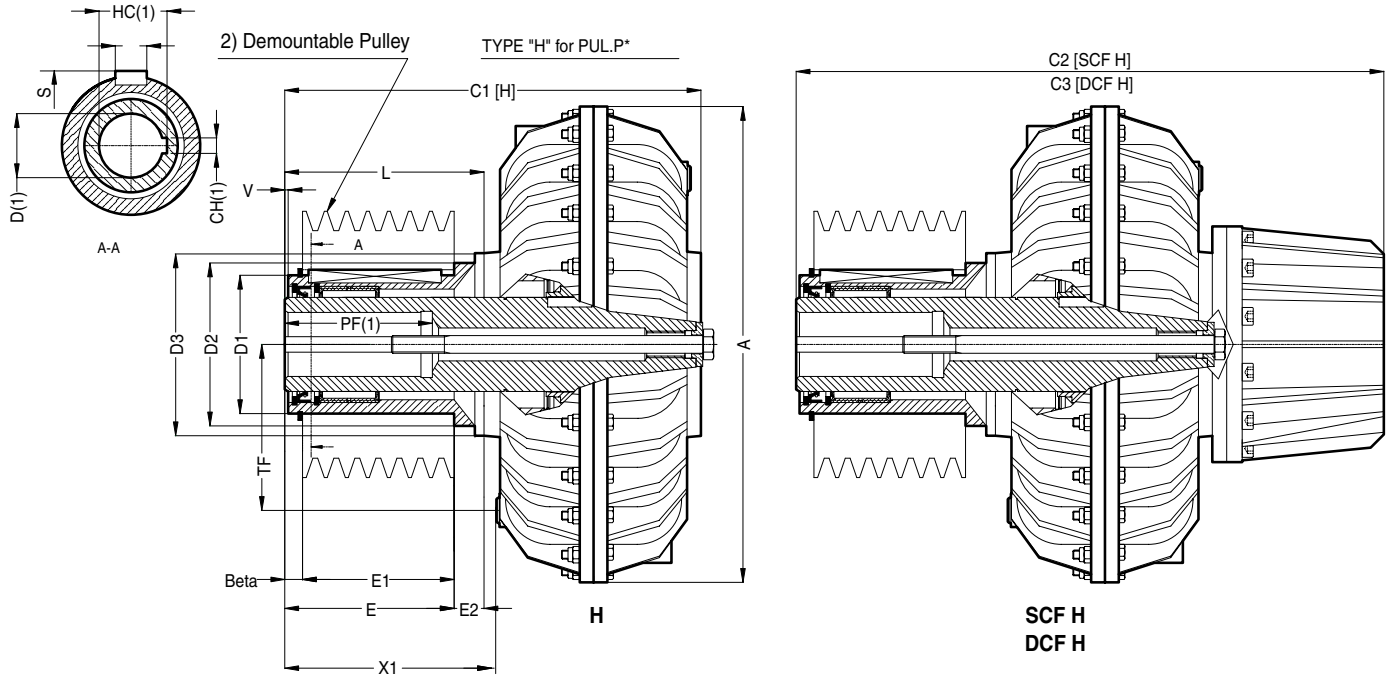

NOTE: (1) FOR BORE AND KEYWAY DIMENSIONS SEE SHEET. 10-019D

Size	H														SCF H			DCF H				
	Dimensions mm														Weight	Dimensions mm		Weight	Dimensions mm		Weight	
	Type	D	A	C1	D1 h7	D2	D3	E	E1	E2	(L)	R	S	V	X1	Kg	Type	C2	Kg	Type	C3	Kg. *
20	H 85	28-38-42	229	218	85	90	90	86	70	30	(103)	12	88,3	6	120	9,3	-	-	-	-	-	
30	H 85	28-38-42	290	262	85	90	84	72	40	(112)	12	88,3	4	121	16,7	SCF H 85	317	19	DCF H 85	357	19,7	
	H 95	48		264	95	105	117	86	72	38	(114)	12	98,3	8	123	18	SCF H 95	319	20,4	DCF H 95	359	21
	H 110	42-48-55		285	110	117	116,5	105	30	(135)	16	114,3	4	144	20	SCF H 110	340	22,4	DCF H 110	380	23	
30P	H 85	28-38-42	327	262	85	90	84	72	40	(112)	12	88,3	4	116	24,7	SCF H 85	317	27	SCF H 85	357	27,7	
	H 95	48		264	95	105	117	86	72	38	(114)	12	98,3	8	118	26	SCF H 95	319	28,4	DCF H 95	359	29
	H 110	42-48-55		285	110	117	116,5	105	30	(135)	16	114,3	4	139	28	SCF H 110	340	30,4	DCF H 110	380	31	
40P	H 110	38-42-48-55-60	338	301	110	145	145	124	112	21	(118)	16	114,3	4	142	27,6	SCF H 110	359	31,5	DCF H 110	431	32,8
	H 125	38-42-48-55-60		325	125	138	145	134	120	32	(142)	18	129,4	6	166	31,3	SCF H125	383	35	DCF H125	455	36,5
50	H 125	42-48-55-60-65	430	334	125	165	170	153	140	39	(180)	18	129,4	3	186	41,8	SCF H 125	414	47,5	DCF H 125	489	49,8
55	H 125	42-48-55-60-65	430	396	125	165	170	173	140	39	(200)	18	129,4	23	206	52	SCF H 125	476	57,8	DCF H 125	551	60
	H 150	75		426	150	170	173	140	87	(230)	16	154,3	236	60	236	60	SCF H150	506	65,8	DCF H150	581	68
60	H 150	48-55-60-65-75-80	520	402	150	179	188	203	190	33	(230)	16	154,3	3	236	70	SCF H 150	492	78,4	DCF H 150	572	82
65	H 150	55-60-65-75-80	520	475	150	179	188	228	190	33	(255)	16	154,3	28	261	93	SCF H 150	565	101,4	DCF H 150	645	105
70P	H 200	75-80-90-100	640	485	200	215	227	245	190	34	(275)	20	204,8	45	275	131	SCF H 200	595	144	DCF H 200	710	151
75P	H 200	80-90-100	640	535	200	215	227	245	190	34	(275)	20	204,8	45	275	174	SCF H 200	645	187	DCF H 200	760	194

* Weight with oil - Standard bores in heavy type

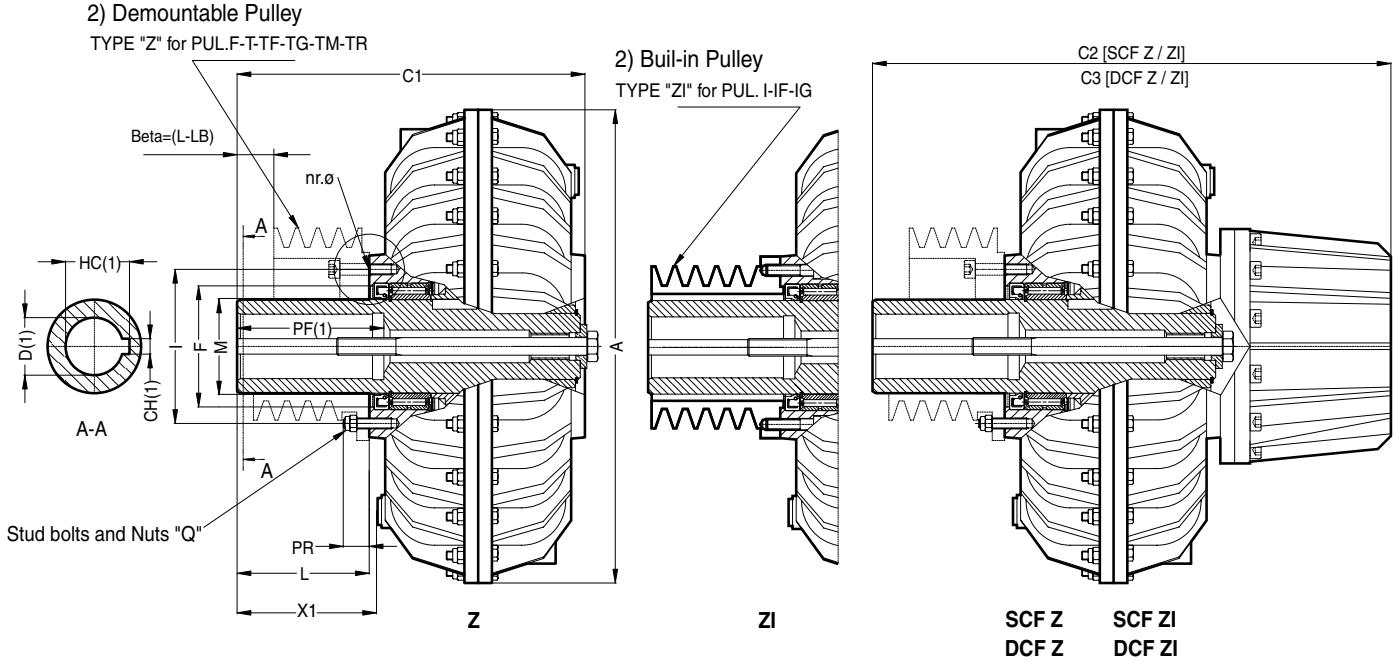

NOTE: 1) FOR BORE AND KEYWAY DIMENSIONS SEE SHEET. 10-019D

2) FOR THE CHOICE OF THE ASSEMBLING COUPLING-PULLEY, SEE "WESTCAR PULLEYS" CATALOGUE

Size	Z / ZI											SCF Z / ZI				DCF Z / ZI				
	Dimensions mm.											Weight Kg. *	Dimensions mm.			Weight Kg. *	Dimensions mm.			Weight Kg. *
	Type	D	A	C1	F H7	I	L	M	PR	nr. ∅	X1		Type	C2	Type		C3			
10	Z 45	-	14-19-24	133	47	60	45	35	14	6-M6	47	4,2	-	-	-	-	-	-	-	
	Z 55	ZI 55	14-19-24	192	143	47	60	55	35	14	57	4,2	-	-	-	-	-	-	-	
	Z 56	ZI 56	28	144	52	68	56	40			58									
20	Z 55	-	19-24-28	170			55	45			62	6,2	-	-	-	-	-	-	-	
	Z 70	ZI 70	19-24-28	230	185	62	78	70	45	18	77	6,2	-	-	-	-	-	-	-	
	Z 69	ZI 69	38	184			69	53			76									
30	Z 68	-		218			68				77	13,5	SCF Z 68	SCF ZI 68	273	15,9	DCF Z 68	DCF ZI 68	313	16,5
	Z 88	-	28-38-42	290	238	75	100	88	60	18	97	13,8	SCF Z 88	SCF ZI 88	293	16,2	DCF Z 88	DCF ZI 88	325	16,8
	Z 112	ZI 112		262			112				121	14	SCF Z 112	SCF ZI 112	317	16,4	DCF Z 112	DCF ZI 112	357	17
30P	Z 68	ZI 68		218			68				72	21,5	SCF Z 68	SCF ZI 68	273	23,9	DCF Z 68	DCF ZI 68	313	24,5
	Z 88	ZI 88	28-38-42	327	238	75	100	88	60	18	92	21,8	SCF Z 88	SCF ZI 88	293	24,2	DCF Z 88	DCF ZI 88	325	24,8
	Z 112	ZI 112		262			112				116	22	SCF Z 112	SCF ZI 112	317	24,4	DCF Z 112	DCF ZI 112	357	25
40P	Z 64	-		247			64				88	22,5	SCF Z 64	SCF ZI 64	305	26,2	DCF Z 64	DCF ZI 64	377	27,7
	Z 90	-	38-42-48-55-60	338	273	100	125	90	80	25	114	23	SCF Z 90	SCF ZI 90	331	25,7	DCF Z 90	DCF ZI 90	403	28,2
	Z 118	ZI 118		301			118				142	23,5	SCF Z 118	SCF ZI 118	359	27,2	DCF Z 118	DCF ZI 118	431	28,7
50	Z N90	-	42-48-55-60-65	430	244	110	140	90	85	25	96	32,5	SCF Z N90	SCF ZI N90	324	38,3	DCF Z N90	DCF ZI N90	399	40,5
	Z N120	ZI N120		274			120				126	33,5	SCF Z N120	SCF ZI N120	354	39,3	DCF Z N120	DCF ZI N120	429	41,5
55	Z N90	-		286			90				96	41	SCF Z N90	SCF ZI N90	366	46,8	DCF Z N90	DCF ZI N90	441	49
	Z N120	-	42-48-55-60-65	430	316	110	140	120	85	25	126	42	SCF Z N120	SCF ZI N120	396	47,8	DCF Z N120	DCF ZI N120	471	50
	Z N155	ZI N155		351			155				161	43	SCF Z N155	SCF ZI N155	431	48,8	DCF Z N155	DCF ZI N155	506	51
60	Z N130	-	48-55-60-65-75-80	520	302	125	160	130	110	25	136	50	SCF Z N130	-	392	58,4	DCF Z N130	-	472	62
65	Z N170	-	55-60-65-75-80	520	390	125	160	170	110	25	176	72	SCF Z N170	-	480	80,4	DCF Z N170	-	560	84

* Weight with oil - Standard bores in heavy type

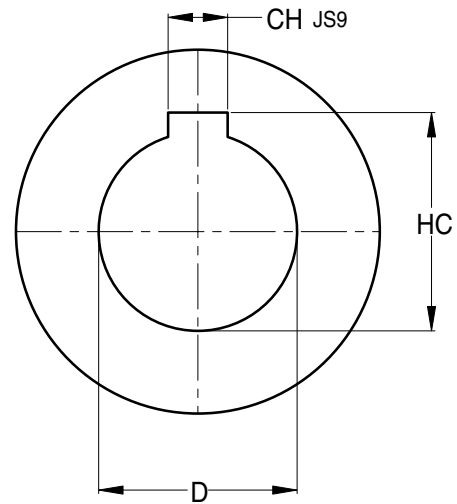
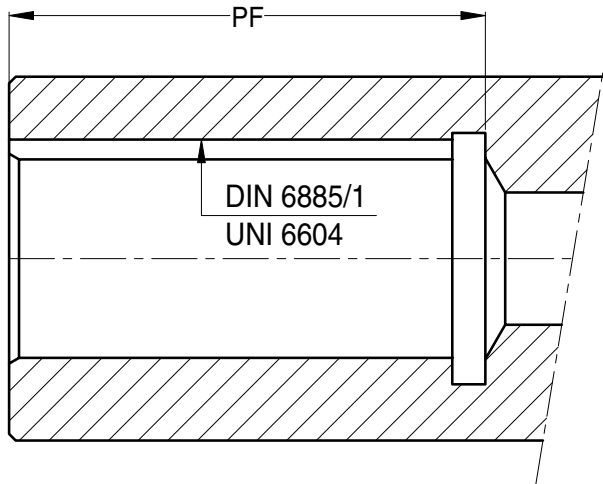

D	Toll.	PF	CH	HC	Toll.
10	H7	25	3	11,4	+0,1 0
11 *		25	4	12,8	
12		25	4	13,8	
13		32	5	15,3	
14 *		32	5	16,3	
15		32	5	17,3	
16		32	5	18,3	
17		42	5	19,3	
18		42	6	20,8	
19 *		45	6	21,8	
20		45	6	22,8	
21		45	6	23,8	
22		55	6	24,8	
23		55	8	26,3	
24 *		55	8	27,3	
25		55	8	28,3	
26		65	8	29,3	
27		65	8	30,3	
28 *		65	8	31,3	
30	65	8	33,3		
32	G7	65	10	35,3	+0,2 0
33		82	10	36,3	
34		82	10	37,3	
35		82	10	38,3	
38 *		82	10	41,3	

D	Toll.	PF	CH	HC	Toll.
40	G7	112	12	43,3	+0,2 0
42 *		112	12	45,3	
45		112	14	48,8	
48 *		112	14	51,8	
50		112	14	53,8	
55 *		112	16	59,3	
60 *		142	18	64,4	
65 *		142	18	69,4	
70 *		142	20	74,9	
75 *		142	20	79,9	
80 *		172	22	85,4	
85 *		172	22	90,4	
90 *		172	25	95,4	
95		172	25	100,4	
100 *		212	28	106,4	
105		212	28	111,4	
110 *		212	28	116,4	
115		212	32	122,4	
120		252	32	127,4	
125 *		252	32	132,4	
130	252	32	137,4		
135 *	252	36	143,4		
140	252	36	148,4		
160	252	40	169,4		
180	252	45	190,4		

* STANDARD BORES FOR UNEL MEC ELECTRIC MOTORS

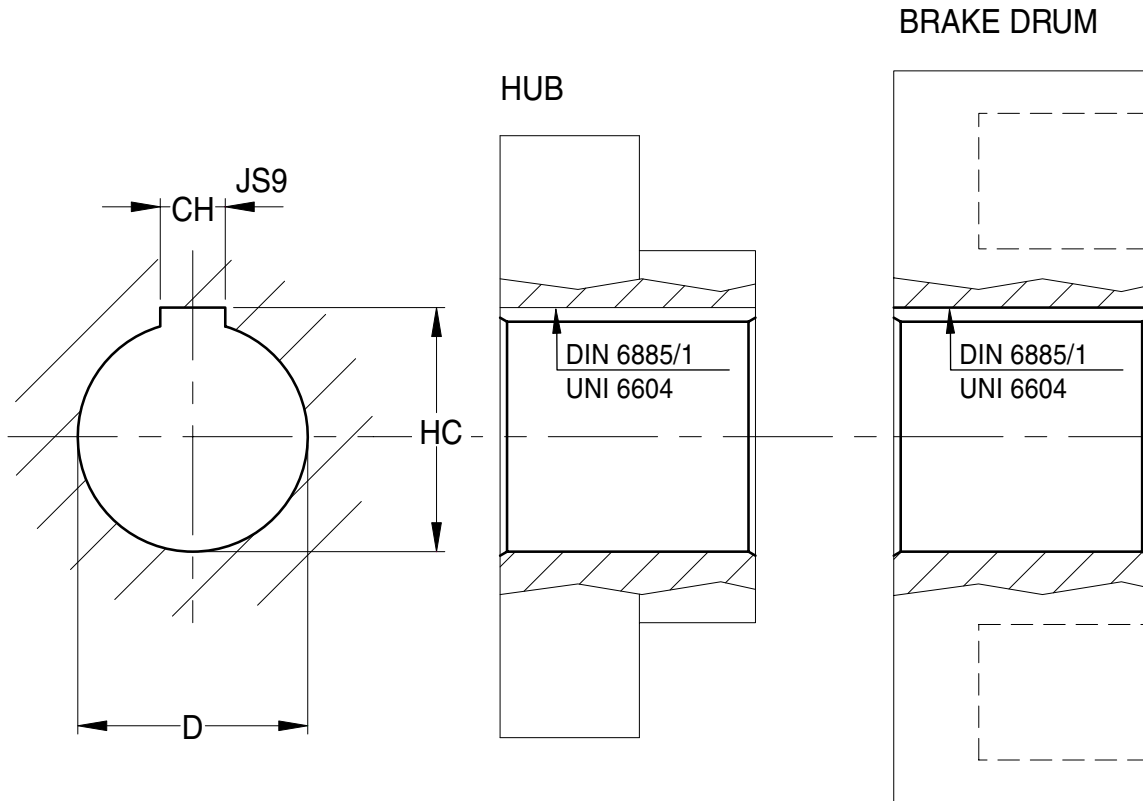

D	Toll.	CH	Toll.	HC	Toll.
10		3		11,4	
11 *		4		12,8	
12		4		13,8	
13		5		15,3	
14 *		5		16,3	+ 0,1
15		5		17,3	0
16		5		18,3	
17		5		19,3	
18		6		20,8	
19 *		6		21,8	
20	H7	6	JS9	22,8	
21		6		23,8	
22		6		24,8	
23		8		26,3	
24 *		8		27,3	
25		8		28,3	
26		8		29,3	
27		8		30,3	+0,2
28 *		8		31,3	0
30		8		33,3	
32		10		35,3	
33		10		36,3	
34	H7	10		37,3	
35		10		38,3	
38 *		10		41,3	

D	Toll.	CH	Toll.	HC	Toll.
40		12		43,3	
42 *		12		45,3	
45		14		48,8	
48 *		14		51,8	
50		14		53,8	
55 *		16		59,3	
60 *		18		64,4	
65 *		18		69,4	
70 *		20		74,9	
75 *		20		79,9	
80 *	H7	22	JS9	85,4	
85 *		22		90,4	
90 *		25		95,4	+0,2
95		25		100,4	0
100 *		28		106,4	
105		28		111,4	
110 *		28		116,4	
115		32		122,4	
120		32		127,4	
125 *		32		132,4	
130		32		137,4	
135 *		36		143,4	
140		36		148,4	
160		40		169,4	
180		45		190,4	

* STANDARD BORES FOR UNEL MEC ELECTRIC MOTORS

OIL CHANGE:

The oil in the coupling must be changed for the first time after 2000 working hours and subsequently after each 4000 working hours.

Proceed as follows to change the oil:

- 1) Rotate the coupling to bring the filling plug to its highest position.
 - 2) Unscrew and remove the filling plug.
 - 3) Determine the correct filling level by rotating the coupling until the filling hole corresponds to the current oil level.
 - 4) Completely drain the oil in the coupling by bringing the filling hole to its lowest point.
 - 5) Rotate the coupling again to bring the filling hole to correspond to the filling level determined at point 3.
 - 6) Pour in the new oil until the oil filling level is reached
- The quantity and type of oil recommended is listed in Table 1.

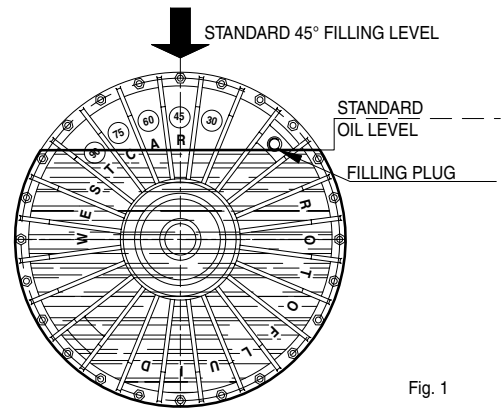

Fig. 1

VARIATION OF THE OIL LEVEL (Figures 1 and 2)

According to the type of use and the service required by the coupling, sometimes the oil filling level must be modified by increasing or decreasing the oil quantity.

The following results are achieved by decreasing the oil quantity:

- Slower and more gradual startings (Fig. 3).
- Less absorption of starting current.
- Better protection to the transmission elements in the event of overload.
- Higher slip value at running.

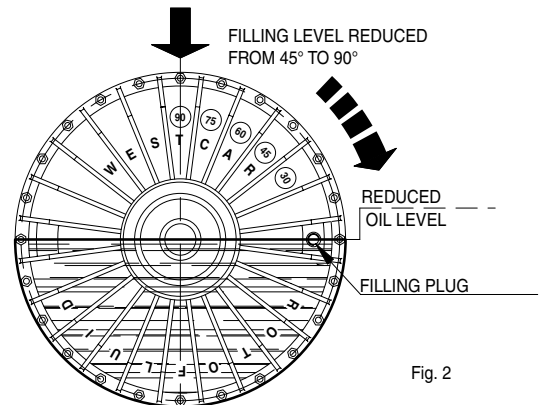

Fig. 2

IMPORTANT:

An excessive decrease in the oil quantity can cause the following problems:

- The impossibility of rapidly accelerating the machine due to insufficient torque.
- The overheating of the coupling, with consequent damage to the oil seals.

The following results are achieved by increasing the oil quantity:

- Faster startings (Fig. 3).
- Lower slip value at running.
- Higher absorption of starting current during acceleration phases.
- Greater strain on transmission elements.

IMPORTANT:

An excessive oil quantity can cause the following problems:

- The overloading of the electric motor.
- The overturning of the oil seal lip due to internal overpressure.
- The cracking of the coupling housing due to internal overpressure caused by the lack of internal space for sufficient oil expansion.

NOTE: the filling level at 45° must never be exceeded, and a level at 30° can be reached only in special cases and after previous WESTCAR consult.

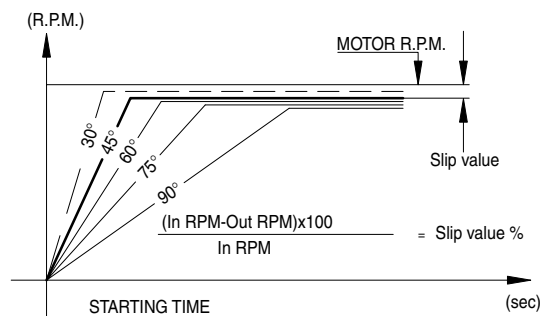

Fig. 3

Tab. 1

Types of oil recommended for standard working temperature from -20°C. to +180°C.

- BP ENERGOL HPL 22÷32
- CASTROL HYPIN AWS 22÷32
- ESSO SPINASSO 22÷32
- MOBIL VELOCITE OIL D
- OLEOTECNICA MOVO H 22÷32
- SHELL TELLUS OIL 22÷32

Types of oil can work continually (longer 5 days) working temperature from -15°C. to +180°C.

- BP ENERGOL HLP Z 46
- CASTROL HYPIN AWS 46
- ESSO NUTO H 46
- MOBIL DTE 25
- OLEOTECNICA MOVO H 46
- SHELL TELLUS 46

The coupling can be also supplied with fire-proof oil or for low temperature one (-40°C.). For more information, consult WESTCAR.

SIZE	OIL QUANTITIES CORRESPONDING TO DIFFERENT FILLING LEVELS									
	30°		45°		60°		75°		90°	
	Kg	Lt.	Kg	Lt.	Kg	Lt.	Kg	Lt.	Kg	Lt.
10	0,53	0,61	0,48	0,55	0,41	0,47	0,35	0,40	0,28	0,32
20	1,15	1,32	1,05	1,20	0,90	1,03	0,76	0,86	0,62	0,71
30	2,28	2,61	2,09	2,39	1,78	2,04	1,46	1,67	1,18	1,34
30P	3,88	4,43	3,55	4,05	3,02	3,46	2,48	2,83	1,98	2,27
40P	3,89	4,45	3,56	4,07	3,05	3,48	2,51	2,87	2,03	2,32
50	4,24	4,85	3,84	4,39	3,31	3,78	2,81	3,21	2,33	2,67
55	6,98	7,98	6,29	7,19	5,43	6,21	4,65	5,31	3,88	4,44
60	8,29	9,47	7,53	8,61	6,41	7,32	5,32	6,08	4,33	4,95
65	13,04	14,91	11,80	13,48	10,01	11,44	8,38	9,58	6,86	7,84
70P	16,83	19,23	15,42	17,62	13,18	15,07	10,8	12,34	8,68	9,92
75P	28,18	32,21	25,70	29,37	21,86	24,98	18,06	20,64	14,63	16,72
80P	34,03	38,89	31,09	35,53	26,63	30,43	22,03	25,18	17,92	20,48
85P	58,26	66,59	53,06	60,64	45,30	51,77	37,66	43,04	30,73	35,12
90P	86,83	99,23	80,43	91,92	69,76	79,73	56,31	64,35	44,68	51,06
95P	146,23	167,12	134,16	153,33	115,05	131,48	94,22	107,68	75,88	86,72
1200	199	226	176	200	156	177	132	150	110	125
1200/2	398	452	352	400	312	354	264	300	220	250

OIL CHANGE:

The oil in the coupling must be changed for the first time after 2000 working hours and subsequently after each 4000 working hours.

To change the oil, proceed as follows:

- 1) Rotate the coupling to bring the filling plug to its highest position.
- 2) Unscrew and remove the filling plug.
- 3) Determine the correct filling level by rotating the coupling until the filling hole corresponds to the current oil level.
- 4) Completely drain the oil in the coupling by bringing the filling hole to its lowest point.
- 5) Rotate the coupling again to bring the filling hole to correspond to the filling level determined at point 3.
- 6) Pour in the new oil until the oil filling level is reached.

The quantity and type of oil recommended is listed in Table 1.

VARIATION OF THE OIL LEVEL (Figures 1 and 2)

According to the type of use and the service required by the coupling, sometimes the oil filling level must be modified by increasing or decreasing the oil quantity.

The following results are achieved by decreasing the oil quantity:

- Slower and more gradual startings (Fig. 3).
- Less absorption of starting current.
- Better protection to the transmission elements in the event of overload.
- Higher slip value at running.

IMPORTANT:

An excessive decrease in the oil quantity can cause the following problems:

- The impossibility of rapidly accelerating the machine due to insufficient torque.
- The overheating of the coupling, with consequent damage to the oil seals.

The following results are achieved by increasing the oil quantity:

- Faster startings (Fig. 3).
- Lower slip value at running.
- Higher absorption of starting current during acceleration phases.
- Greater strain on transmission elements.

IMPORTANT:

An excessive oil quantity can cause the following problems:

- The overloading of the electric motor.
- The overturning of the oil seal lip due to internal overpressure.
- The cracking of the coupling housing due to internal overpressure caused by the lack of internal space for sufficient oil expansion.

NOTE: the filling level at 45° must never be exceeded, and a level at 30° can be reached only in special cases and after previous WESTCAR Consult.

Types of oil recommended for standard working temperature from -20°C. to +180°C.

- BP ENERCOL HPL 22÷32
- CASTROL HYSPIAN AWS 22÷32
- ESSO SPINASSO 22÷32
- MOBIL VELOCITE OIL D
- OLEOTECNICA MOVO H 22÷32
- SHELL TELLUS OIL 22÷32

Types of oil recommended for continuous work (over 5 days) temperature -15°C. to +180°C.

- BP ENERCOL HLP Z 46
- CASTROL HYSPIAN AWS 46
- ESSO NUTO H 46
- MOBIL DTE 25
- OLEOTECNICA MOVO H 46
- SHELL TELLUS 46

The coupling can be also supplied with fire-proof oil or for lowtemperature one (-40°C.). For more information, consult WESTCAR.

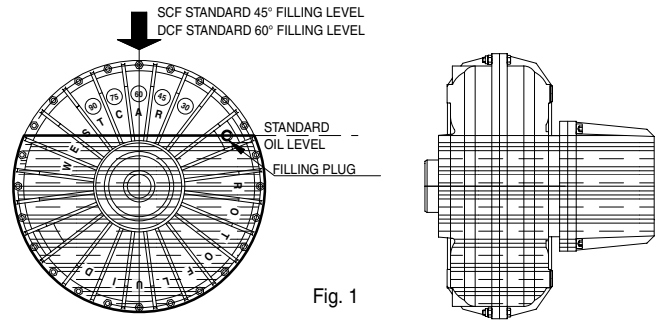

Fig. 1

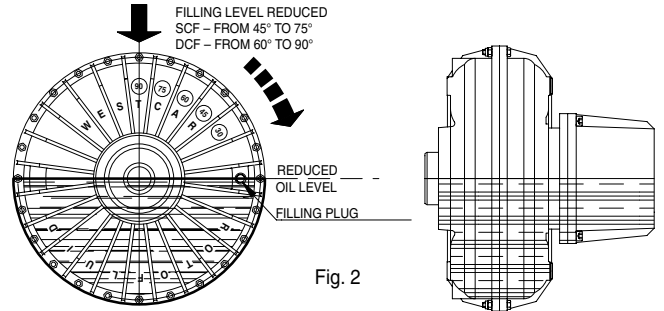

Fig. 2

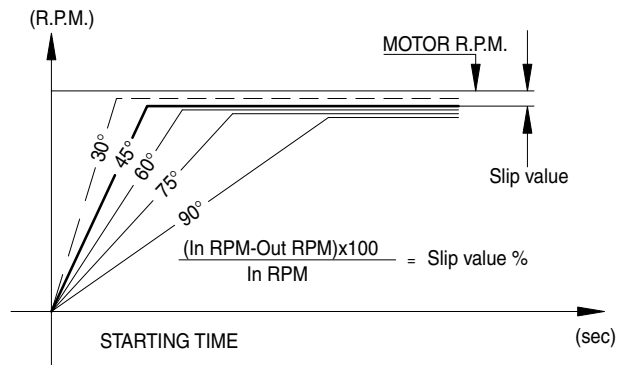
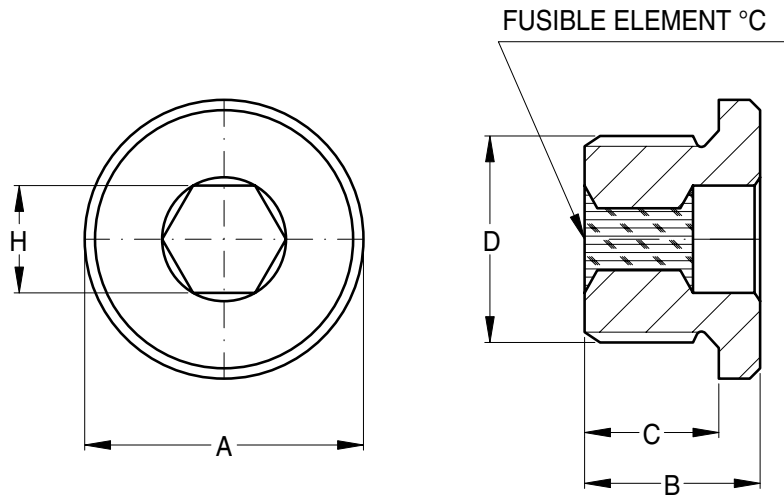

Fig. 3

Tab. 1

SIZE	OIL QUANTITIES CORRESPONDING TO DIFFERENT FILLING LEVELS							
	(Kg. = Litri x 0,875)							
	45° (lt.)		60° (lt.)		75° (lt.)		90° (lt.)	
	SCF	DCF	SCF	DCF	SCF	DCF	SCF	DCF
20	-	-	-	-	-	-	-	-
30	2,65	2,94	2,30	2,58	1,86	2,07	1,47	1,61
30P	4,32	4,62	3,72	4,02	3,04	3,26	2,39	2,53
40P	4,44	5,34	3,84	4,70	3,14	3,78	2,45	2,93
50	5,27	6,36	4,62	5,67	3,83	4,59	3,07	3,56
55	8,06	9,12	7,04	8,05	5,93	6,67	4,84	5,33
60	10,01	11,63	8,71	10,35	7,16	8,41	5,58	6,29
65	14,86	16,42	12,80	14,34	10,65	11,85	8,47	9,20
70P	20,09	23,83	17,51	21,20	14,34	17,32	11,07	12,82
75P	32,96	36,68	27,39	31,02	22,61	25,55	17,87	19,63
80P	42,50	48,45	37,38	43,29	30,58	35,27	23,76	26,57
85P	67,55	73,49	59,54	64,49	48,40	53,08	38,41	41,22
90P	104,80	118,72	91,70	104,61	73,72	83,45	57,25	63,94
95P	178,18	192,94	154,89	168,50	125,43	135,76	98,63	105,81

In case of overheating, the fusible plug allows the oil outlet and disconnect the power transmitted to the output shaft.
Fusible plugs are available for three different melting temperatures: 120°C, 145°C and 180°C.
The standard Couplings are supplied with fusible plug at 145° C.



ROTOFLUID SIZE	PLUG DIMENSIONS					FUSIBLE ELEMENT TEMPERATURE AND COLOUR			WEIGHT Kg
	A	B	C	D	H	WHITE	RED	GREEN	
10	18	15	11	¼ GAS	6	120°C	145°C	180°C	0,016
20	18	15	11	¼ GAS	6	120°C	145°C	180°C	0,016
30	18	15	11	¼ GAS	6	120°C	145°C	180°C	0,016
30P	18	15	11	¼ GAS	6	120°C	145°C	180°C	0,016
40P	18	15	11	¼ GAS	6	120°C	145°C	180°C	0,016
50	26	19	15	½ GAS	10	120°C	145°C	180°C	0,048
55	26	19	15	½ GAS	10	120°C	145°C	180°C	0,048
60	26	19	15	½ GAS	10	120°C	145°C	180°C	0,048
65	26	19	15	½ GAS	10	120°C	145°C	180°C	0,048
70P	26	19	15	½ GAS	10	120°C	145°C	180°C	0,048
75P	26	19	15	½ GAS	10	120°C	145°C	180°C	0,048
80P	26	19	15	½ GAS	10	120°C	145°C	180°C	0,048
85P	26	19	15	½ GAS	10	120°C	145°C	180°C	0,048
90P	32	20	16	¾ GAS	12	120°C	145°C	180°C	0,075
95P	32	20	16	¾ GAS	12	120°C	145°C	180°C	0,075

When ordering specify: dimension "D", fusible plug melting temperature and colour.
EX: Fusible plug _ GAS 145° red.

FUSIBLE PLUG STANDARD POSITION

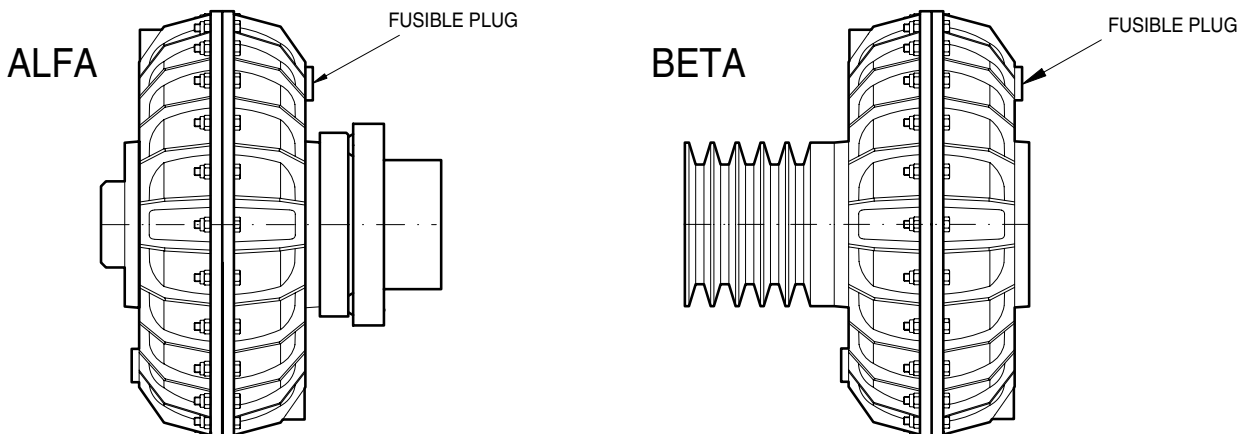

In case of coupling overheating with a thermal trip plug, a pin is released and trips a limit switch which gives an alarm or shut off the electric motor. This method avoids the oil leakage from the coupling.

Fusible trip plugs are available for three different temperatures: 120°C, 145°C and 180°C.

In case of stall conditions, motor running and machine locked, the coupling housing must be driving to guarantee the signal survey.

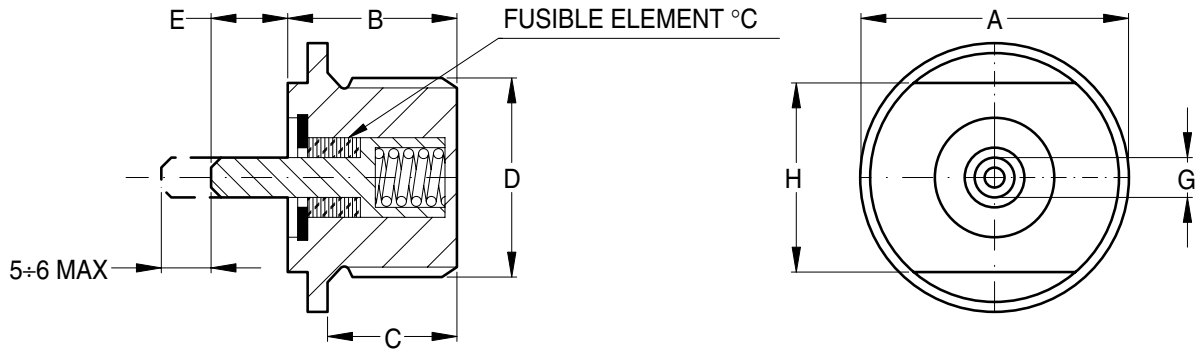

ROTOFLUID SIZE	PLUG DIMENSIONS							FUSIBLE ELEMENT TEMPERATURE AND COLOUR			Weight Kg
	A	B	C	D	E	G	H	WHITE	RED	GREEN	
10	18	19	16	¼ GAS	8	4	14	120°C	145°C	180°C	0,016
20	18	19	16	¼ GAS	8	4	14	120°C	145°C	180°C	0,016
30	18	19	16	¼ GAS	8	4	14	120°C	145°C	180°C	0,016
30P	18	19	16	¼ GAS	8	4	14	120°C	145°C	180°C	0,016
40P	18	19	16	¼ GAS	8	4	14	120°C	145°C	180°C	0,016
50	26	19	15	½ GAS	8	4	19	120°C	145°C	180°C	0,048
55	26	19	15	½ GAS	8	4	19	120°C	145°C	180°C	0,048
60	26	19	15	½ GAS	8	4	19	120°C	145°C	180°C	0,048
65	26	19	15	½ GAS	8	4	19	120°C	145°C	180°C	0,048
70P	26	19	15	½ GAS	8	4	19	120°C	145°C	180°C	0,048
75P	26	19	15	½ GAS	8	4	19	120°C	145°C	180°C	0,048
80P	26	19	15	½ GAS	8	4	19	120°C	145°C	180°C	0,048
85P	26	19	15	½ GAS	8	4	19	120°C	145°C	180°C	0,048
90P	32	20	16	¾ GAS	8	4	22	120°C	145°C	180°C	0,075
95P	32	20	16	¾ GAS	8	4	22	120°C	145°C	180°C	0,075

When ordering specify: dimension "D", safety plug melting temperature and colour.

EX: Fusible trip plug ¼ GAS 145° red.

THERMAL TRIP PLUG STANDARD POSITION

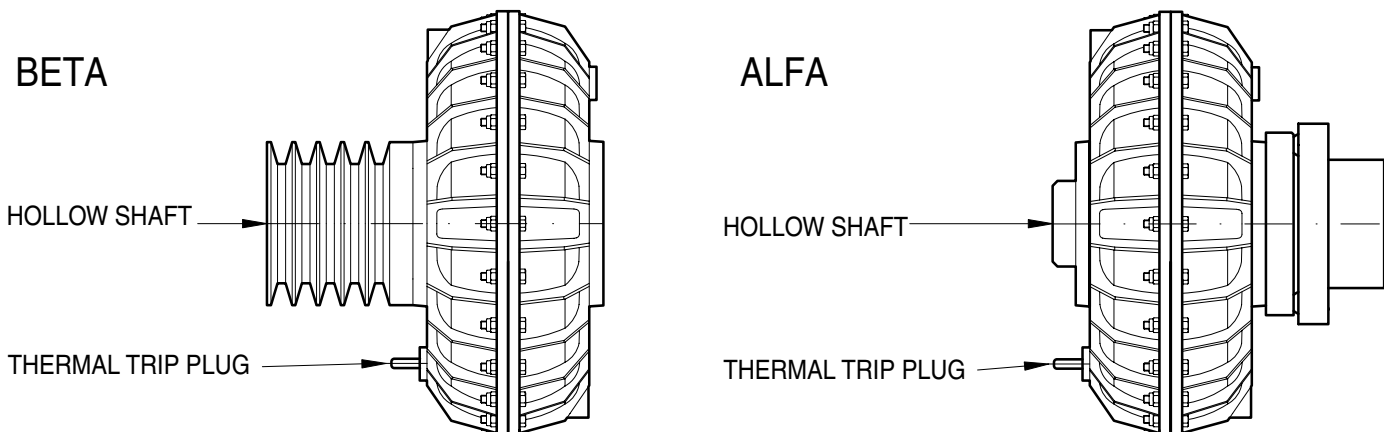

The thermal trip plug is normally mounted by the hollow shaft side but in case of need can be located in the opposite side too.

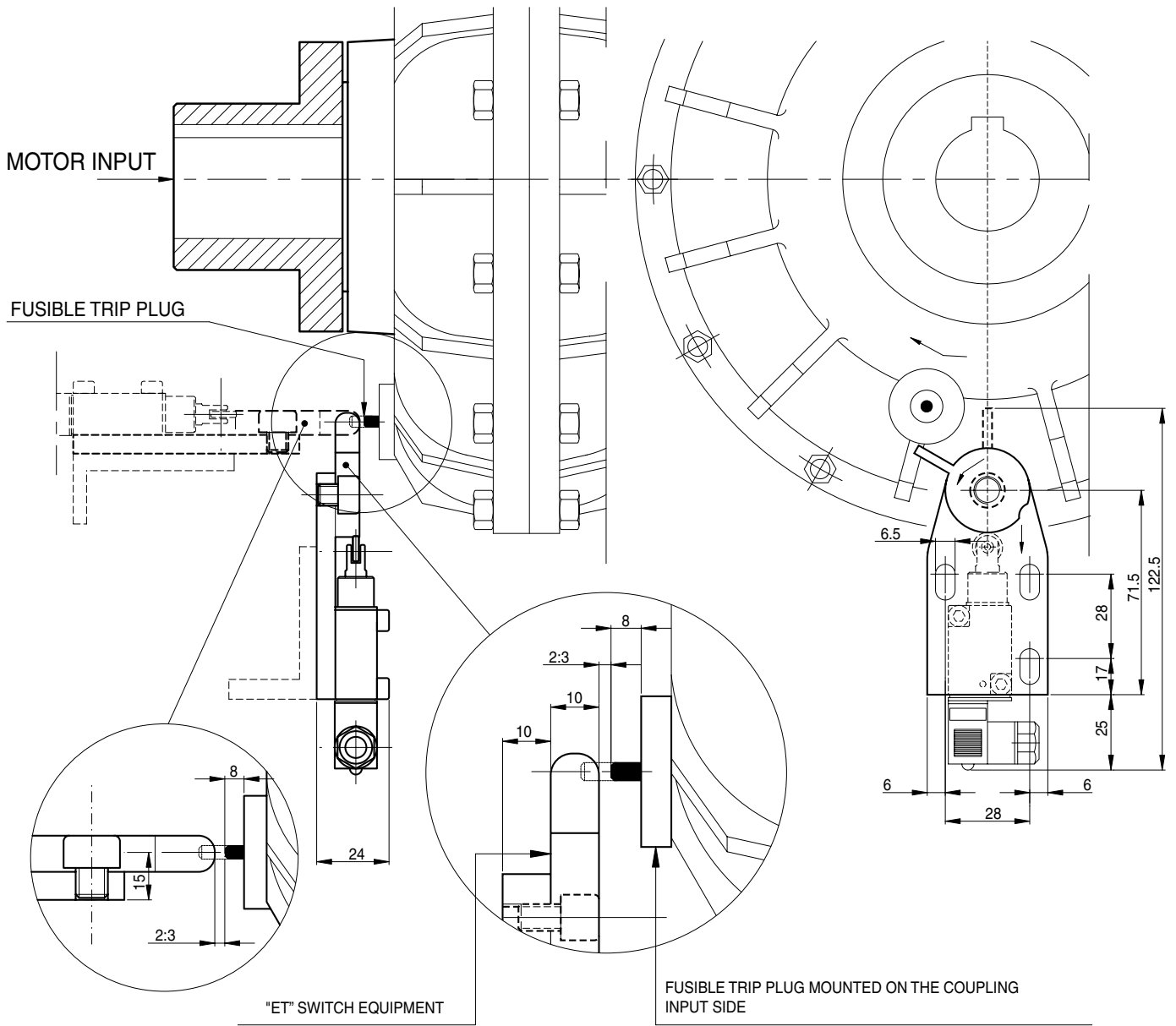

"ET" CONNECTED TO A LIGHT OR SOUND SIGNAL

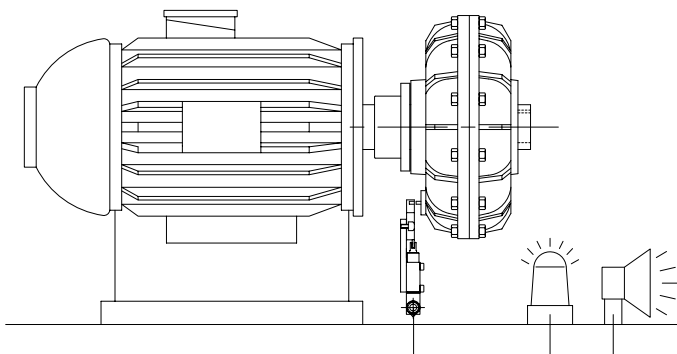

"ET" CONNECTED TO SWITCH OFF THE DRIVE

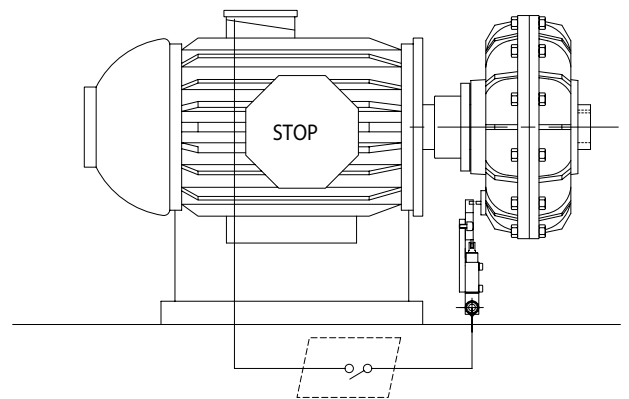

The "ET" safety device consists of a microswitch and a cam mounted on a base and operates in combination with a thermal trip plug fitted on the fluid coupling housing. In case of coupling overheating due to overloads and machine jams or reduced oil filling, the oil temperature can exceed the melting temperature set for the thermal trip plug. The pin then extends and makes contact with the cam of the microswitch sounding an alarm or shutting down the drive.

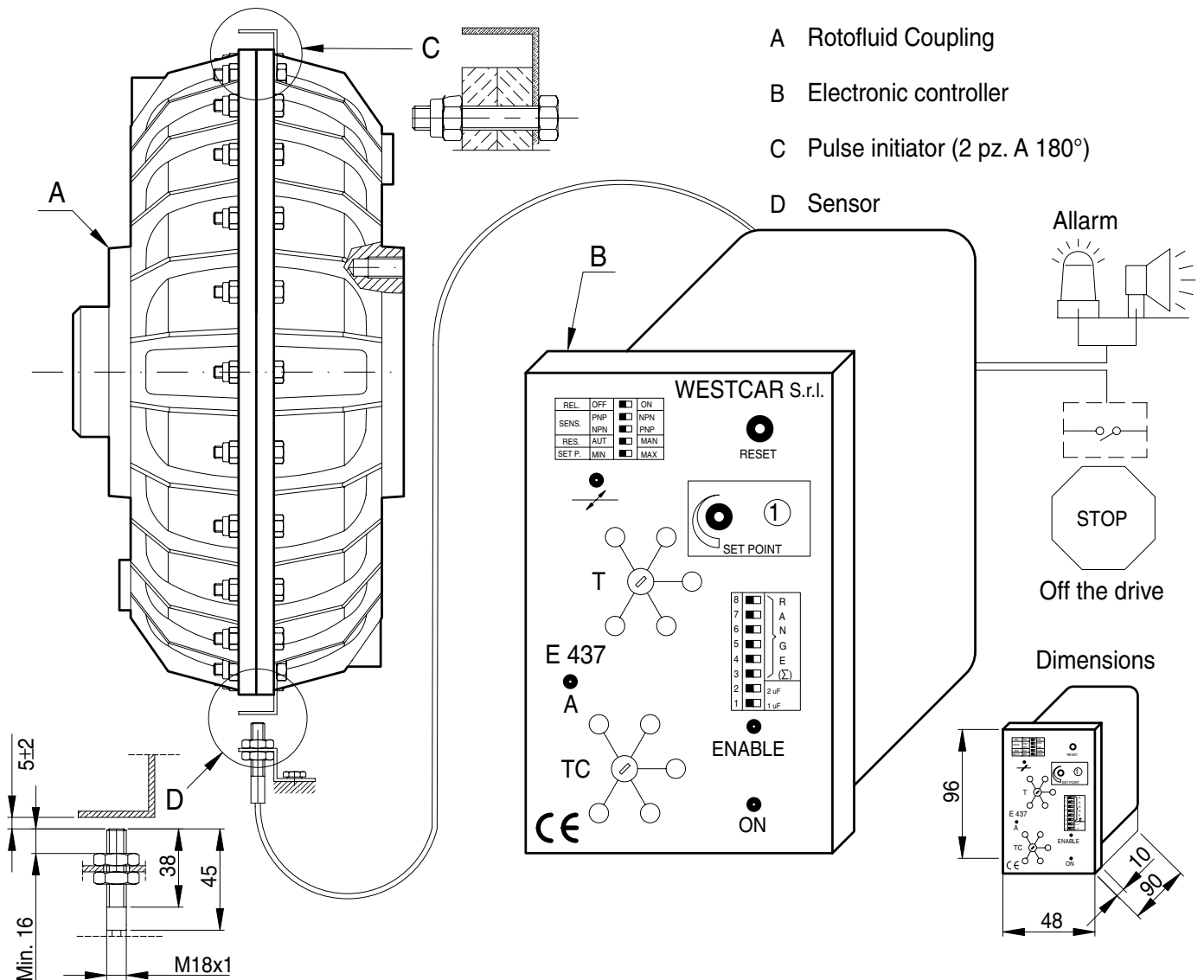

"SCD" DEVICE

The "SCD" Device can be setted to guarantee the safety of coupling and machine and the product quality.

The "SCD" device is an electronic controller which receives a train of pulses by a sensor. The pulses are converted into a voltage proportional to the pulses frequency. This voltage is compared with a variable reference voltage (SET POINT). The internal relay changes over when the input speed is faster or lower than the fixed (SET POINT). It is employed to control the shaft revolution speed. In case of speed decrease, the device gives a signal to the operator.

OPERATION

As the trasmitted torque is increased, this gives rise to an increased slip of the fluid coupling. Possible overload can be detected by measuring the resulting speed reduction in the driven half coupling by means of overload "SCD". This with change-over contact at the output may either emit an alarm signal or switch off the main motor. A delaying action (max 120 sec.) prevent the unnecessary triggering of the relay, when the motor is started. It only occurs once when the operating voltage is applied. False alarms are prevented arising from very short torque fluctuations, by the introduction of a preset time lag (max. 30 sec.)

SUPPLY

50±60 Hz - Tolerance: -10%÷+6% - 24Vac STANDARD (115Vac or 230 Vac on request)- How to order: SCD 24 Vac

TAPPED HOLE DIMENSIONS FOR STANDARD ELECTRIC MOTOR SHAFTS

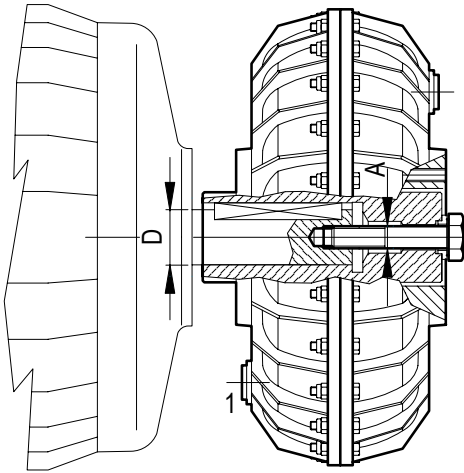

Dimensions "A"	MOTOR SHAFT DIAMETERS "D"									
	Ø 14	Ø 19	Ø 24	Ø 28	Ø 38	Ø 42 Ø 48	Ø 55 Ø 60 Ø 65 Ø 70 Ø 75 Ø 80	Ø 90 Ø 100 Ø 110 Ø 125 Ø 135	Ø 140 Ø 160	
M 5	•									
M 6		•								
M 8			•							
M 10				•						
M 12					•					
M 16						•				
M 20							•			
M 24								•		
M 36									•	

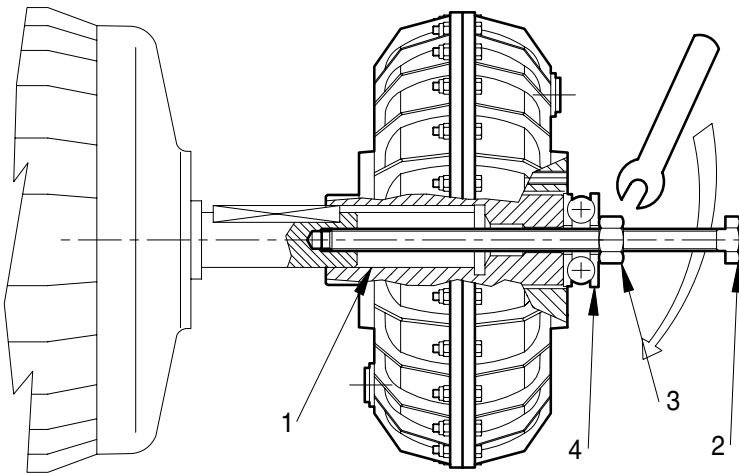

Fig. 1

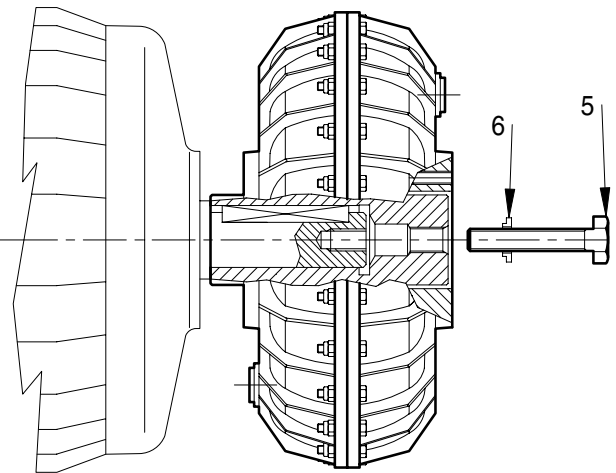

Fig. 2

For the mounting of the ROTOFUID coupling to the motor it is indispensable to operate on the shaft (1) of the coupling to avoid axial stress on the bearings. It is recommended to fix on the motor shaft a screw stay (2) on which a nut (3) is tightened possibly resting to a thrust bearing (4) (see Fig.1).

It is indispensable to lubricate the motor shaft before mounting the coupling.

Check that the coupling shaft rest on the motor shaft shoulder and lock by means of screw (5), spacer (6) (see Fig.2)

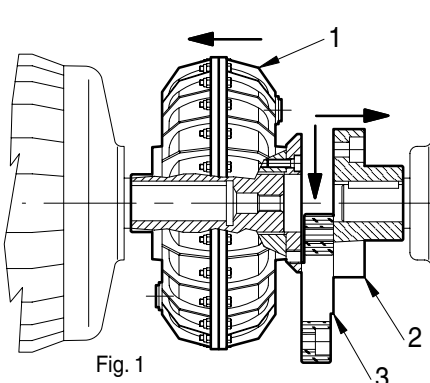

Fig. 1

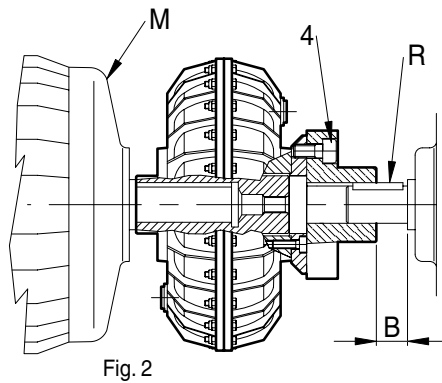

Fig. 2

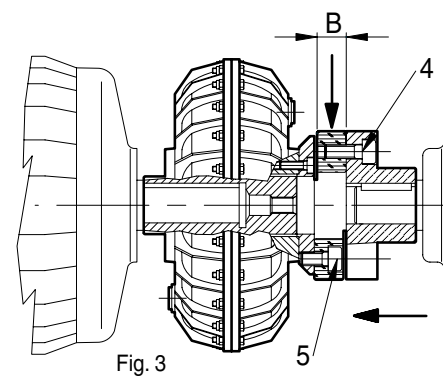
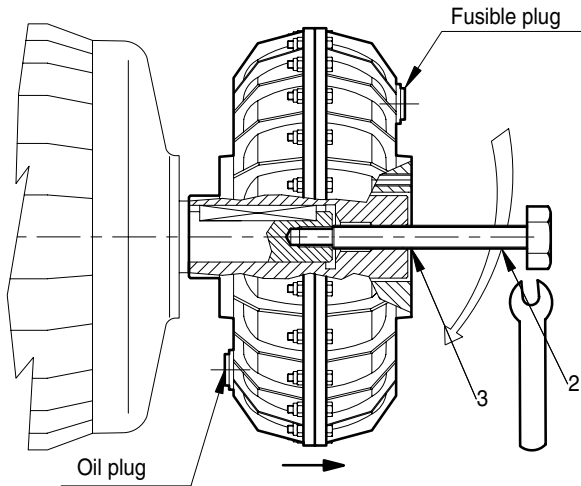

Fig. 3

- 1) Demount the ROTOFLEXI rubber element (F) as shown at Fig.1
- 2) Fit the ROTOFUID hydraulic coupling (A) on the motor shaft(M), fit the ROTOFLEXI hub (B) on the driven shaft ©. Assure that the driven shaft is coaxial with the hydraulic coupling (A). The concentricity is assured when it is possible to fix the hub (B) to the hydraulic coupling flange (A) by means of the screw (D), as shown at Fig.2. It is now possible to fix definitely the motor and the driven machine checking that between the hub (B) and the driven shaft shoulder there must be a space (E) equal to the thickness of the rubber element (F).
- 3) Remove the screws (D), move the hub (B), place the rubber element (F), lock the screws (G) and (H) as shown at Fig.3.

SCREW PULLER "VE" TYPE



- To pull off the ROTOFUID coupling proceed as follows:
- Remove the screw plug or the tightening screw from the shaft end.
- Tight the screw puller in the shaft threaded hole checking that the motor shaft is locked.

ROTOFLUID COUPLING		
SISTEM	SIZE	TYPE
"VE"		K
VE M14	20	K1
VE M16	20	K3
VE M20	20	-
VE M24	30	ALL VERSIONS
	30P	
	40P	
	50	
VE M30	55	UP TO Ø 65 FOR Ø75 Ø 80
	60	ALL VERSIONS
VE M36	65	
	70P	
	75P	
	80P	
	85P	
	90P	
	95P	

PULLING OFF SYSTEM "SE" TYPE

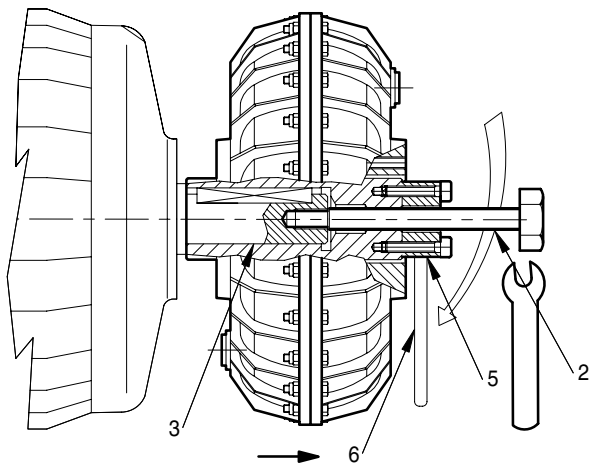

- To pull off the ROTOFUID coupling proceed as follows:
- Remove the screw plug or the tightening screw from the shaft end.
- Lock the bush (5) to the shaft end (3) with 2 securing screws.
- Tight the screw puller (2) in the shaft threaded hole keeping locked the rod (6) to avoid the motor shaft rotation.

ROTOFLUID COUPLING						
SISTEM "SE"	SIZR	TYPE				
		K	Z	J	H	X
SE M20	20	-	-	J 103	H 85	X 103
SE M24/35	30	ALL VERSIONS				
	30P					
	40P					
SE M24/40	50	UP TO Ø 65 FOR Ø75 Ø 80				
	55					
SE M30	60	ALL VERSIONS				
	65					
SE M36	70P					
	75P					
	80P					
	85P					
	90P					
	95P					

PULLING OFF SYSTEM "SE" TYPE

The figure 1 shows ROTOFUID® coupled in line with ROTOFLEXI®. This kind of assembly permits the great advantage to replace the rubber elements without moving the transmission components from their position (Fig.2)

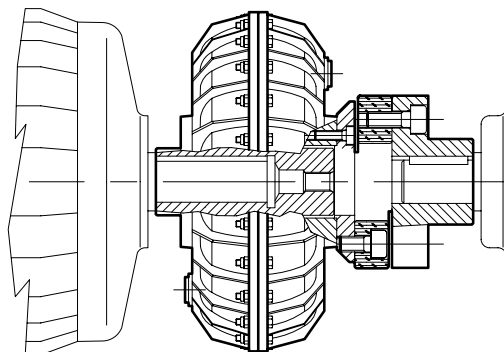

Fig. 1

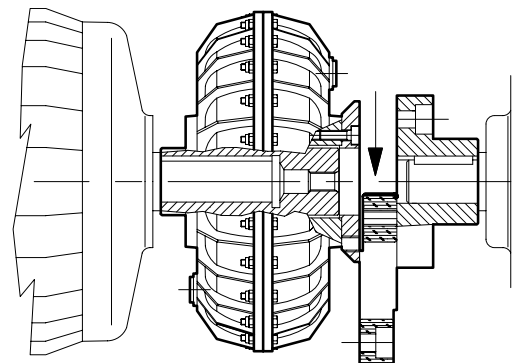

Fig. 2

ROUND SINGLE IMPELLER COUPLINGS

COUPLING ALFA

- 10 K1
- 20 K1
- 30 K1
- 30P K1
- 40P K1

Fig. 1

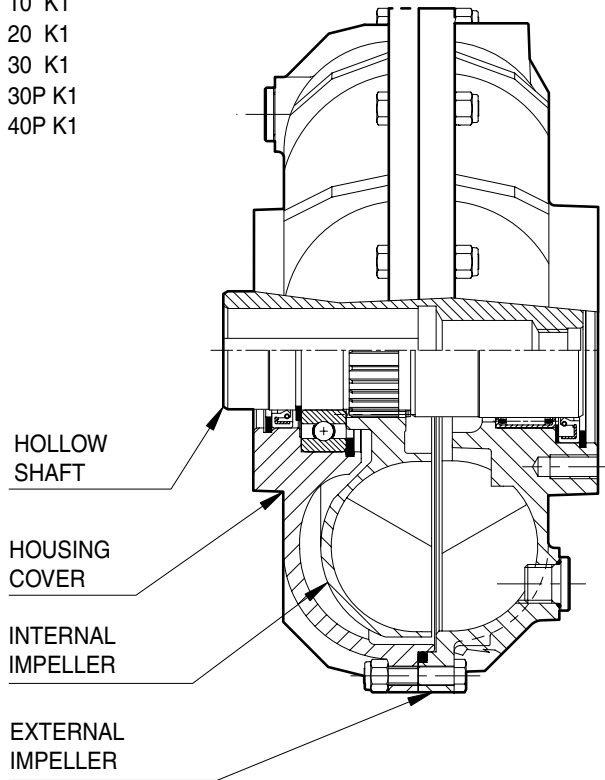

COUPLING ALFA

- 10 K3
 - 20 K3
 - 30 K3
 - 30P K3
 - 40P K2
- COUPLING BETA**
- 10 Z
 - 20 Z
 - 30 Z-X-J-H
 - 30P Z-X-J-H
 - 40P Z-X-J-H

Fig. 2

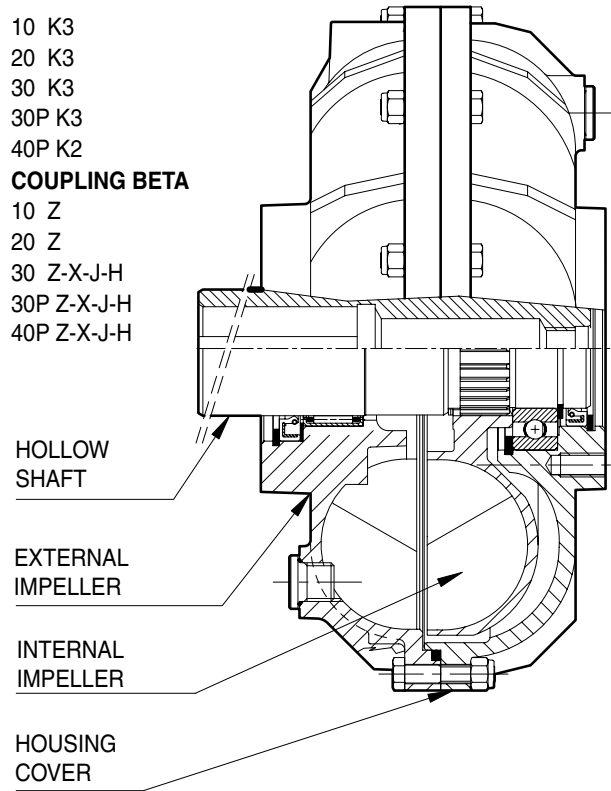

SINGLE IMPELLER COUPLINGS

Fig. 3

COUPLING ALFA

- 50 K2
- 60 K2
- 70P K2
- 80P K2
- 90P K2

COUPLING BETA

- 50 Z-X-J-H
- 60 Z-X-J-H
- 70P Z-X-J-H
- 80P Z-X-J-H

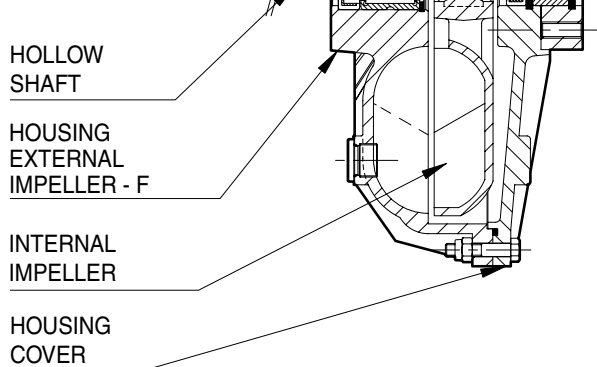

TWIN IMPELLER COUPLINGS

Fig. 4

COUPLING ALFA

- 55 K2
- 65 K2
- 75P K2
- 85P K2
- 95P K2

COUPLING BETA

- 55 Z-X-J-H
- 65 Z-X-J-H
- 75P Z-X-J-H
- 85P Z-X-J-H

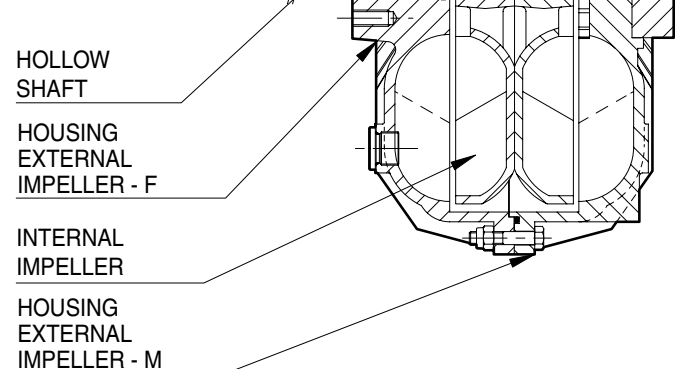

ROTOFLUID
COUPLING

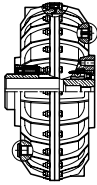

ROTOFLUID SCF
COUPLIG

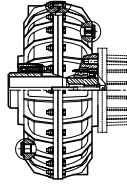

ROTOFLUID DCF
COUPLING

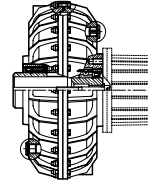

SPARE PARTS FOR ALFA AND BETA COUPLINGS

1 OILSEALS KIT

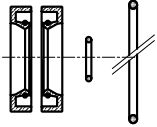

2 BEARINGS KIT

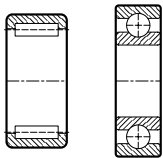

3 SEEGER RINGS KIT

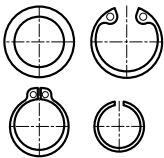

4 NUTS KIT

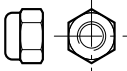

5 OIL PLUG AND SCREWS KIT

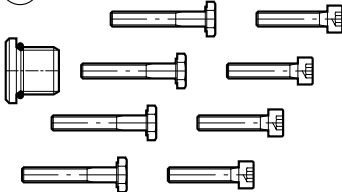

6 FUSIBLE PLUG (1)



(1) QUOTE TEMPERATURE
120 °C - 145 °C - 180 °C

7 THERMAL TRIP PLUG (1)



(1) QUOTE TEMPERATURE
120 °C - 145 °C - 180 °C

ALFA COUPLING AND FLEXIBLE COUPLING

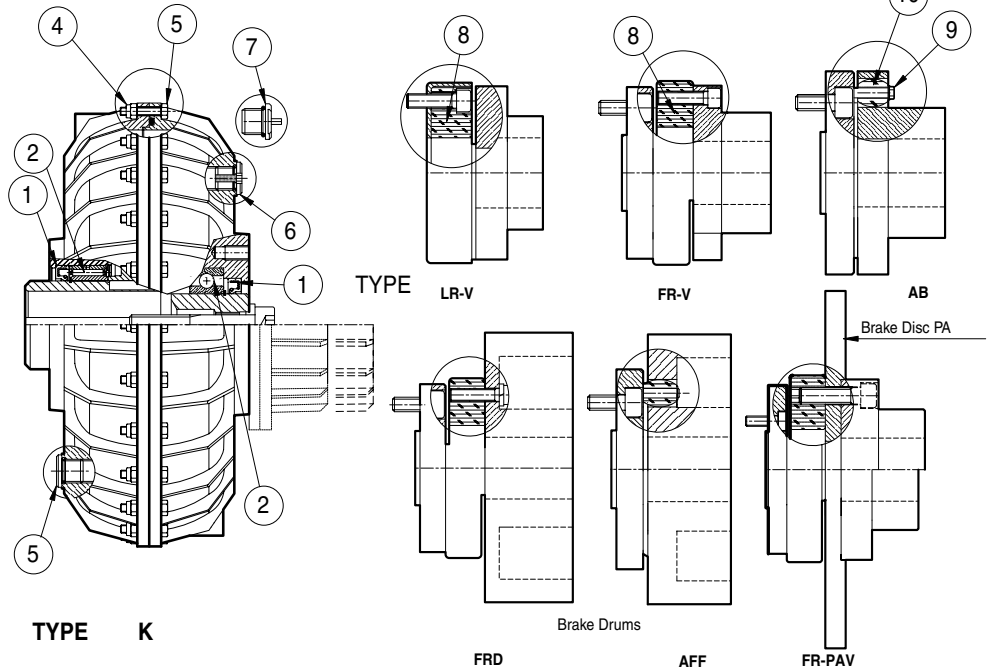

BETA COUPLING

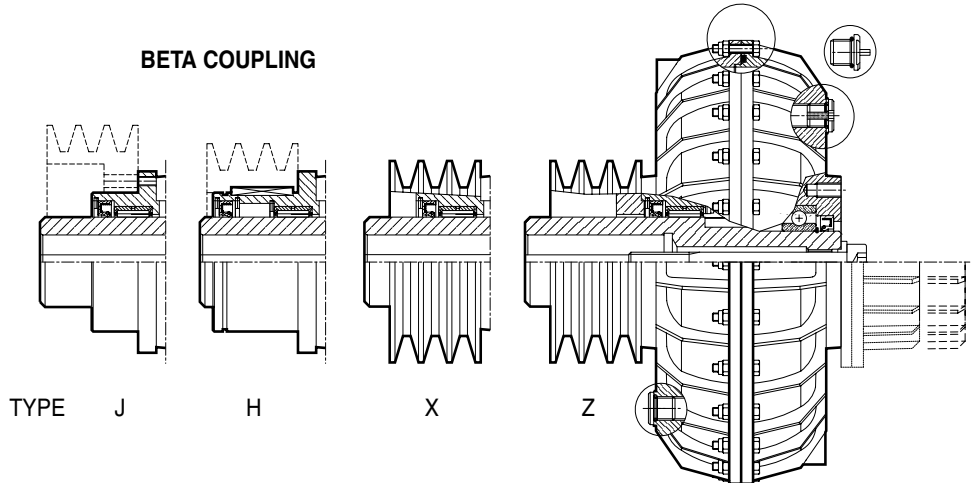

SPARE PARTS FOR FLEXIBLE COUPLING

8 FLEXIBLE COUPLING WITH SCREW



FOR ROTOFLEXI
COUPLINGS

LRV
FRV
FRD
FR-PAV

9 PINS WITH RUBBER

FOR ROTOPIN COUPLINGS
AB
AFF

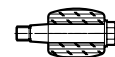

10 RUBBER BUFFER

FOR ROTOPIN COUPLINGS
AB
AFF



For transmission oil characteristic see installation and maintenance manual.
To order spare parts indicate coupling type and identification code or see pag.3 of instruction manual.

THE OPTIONAL FUNCTIONS
WILL MODIFY THE BASIC
CODE OF THE
STANDARD COUPLING

ROTOFLUID COUPLING

OPTIONAL FUNCTIONS

SIZE	VERSION	HOLE
		BORE D

HORIZONTAL SHAFT
MOUNTING

VERTICAL SHAFT MOUNTING
MOTOR SHAFT UP WARDS

VERTICAL SHAFT MOUNTING
MOTOR SHAFT DOWN WARDS

OIL FILLING PLUG PARALLEL
TO THE COUPLING SHAFT

OIL FILLING PLUG RADIAL
TO THE COUPLING SHAFT

NBR OIL SEALS FOR MAX. 120°C
(WITHOUT STRENGTHENING RINGS)

VITON OIL SEALS FOR
MAX 200°C

STRENGTHENING AND PROTECTING
RINGS FOR OIL SEALS

OIL FOR TEMPERATURES FROM
-20°C TO +180°C.
NONFLAMMABLE OIL (I)
OIL FOR TEMPERATURES FROM
-40°C TO +160°C (B)

BEARINGS LUBRICATION WITH
TRANSMISSION OIL

FORCED BEARINGS LUBRICATION
WITH GREASE/OIL

COUPLING ARRANGED FOR
DISASSEMBLING WITH EXTRACTION
SCREW

COUPLING ARRANGED FOR
DISASSEMBLING WITH
"S.E." SYSTEM (E)

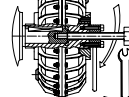
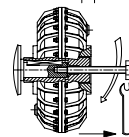
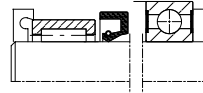
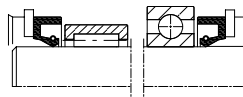
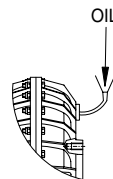
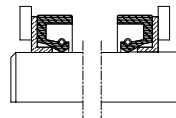
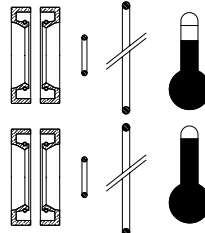
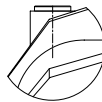
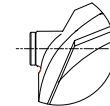
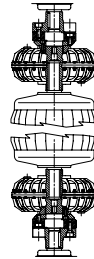
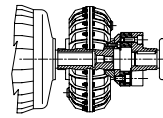

Standard

C1

C2

Standard

R

C1 Standard

V

ZZ

Standard

I

B

Standard

G

Standard

E

FIELDS OF APPLICATION

Building-Construction-Surface Mining-Bricks

- Tower cranes
- Bridge cranes
- Belt conveyors
- Armored chain conveyors
- Screw conveyors
- Slat conveyors
- Bucket wheel excavators
- Bucket elevators
- Concrete mixers
- Rotating screens
- Rolling mills
- Brick moulders
- Power trowels
- Stone crushers
- Centrifuge for concrete piles
- Hammer and barrel mills

Textile

- Drum tumblers
- Centrifuges
- Industrial washing machines
- Driers
- Carding machines
- Spinning machines
- Combing machines
- Raising machines

Chemical – Foodstuff

- Centrifuges
- Centrifugal separators
- Decanters
- Rotating filters
- Mixers
- Stirrers
- Soap cutters
- Bottling plants
- Disc driers
- Waste slaughterhouses braker

Mechanical Engineering

- Twisting machines for rope and wire
- Rod iron straighteners
- Presses
- Profiling machines
- Drawbenches
- Cutters

Automotive Industry

- Balancing machines
- Tow conveyors
- Overhead chain conveyors
- Gates open/closing drive
- Chain conveyors
- Car parking elevators

Paper Processing

- Winders
- Pulpers
- Cardboard making machinery
- Mixers

Timber Processing

- Drum barkers
- Hardboard presses
- Shredders
- Plywood presses

Plastic and Rubber

- Crushers
- Screw extruders
- Calenders
- Rolling presses
- Mixers
- Muddlers

Cement Mill

- Rotating kilns
- Belt conveyors
- Bucket elevators
- Fan blowers

Marble

- Gantry cranes
- Multi-blade frames
- Diamond wire saw

Ceramics

- Continuous and intermittent ball mills
- Mixers
- Presses

The Ecology

- Blenders
- Sludge purification plant

Others

- Winches
- Windlasses
- Centrifugal and alternative compressors
- Suction and centrifugal fans
- Centrifugal pumps
- Fire pumps
- Elevators
- Cable cars
- Amusements park rides
- Haulage wagons in steelworks and mines
- Stack-up coating plants
- Sprayers
- Refineries
- Ski lift
- Sand mixers

APPLICATIONS



Elevator winch



Rotating dryer



Shredder



Belt conveyor





WESTCAR WORLD WIDE

- | | | |
|---|--|---------------------------------------|
| <input type="checkbox"/> Australia | <input type="checkbox"/> Great Britain | <input type="checkbox"/> Romania |
| <input type="checkbox"/> Austria | <input type="checkbox"/> Holland | <input type="checkbox"/> Singapore |
| <input type="checkbox"/> Belgium | <input type="checkbox"/> Hungary | <input type="checkbox"/> Slovenja |
| <input type="checkbox"/> Canada | <input type="checkbox"/> India | <input type="checkbox"/> South Africa |
| <input type="checkbox"/> Ceka Republik | <input type="checkbox"/> Indonesia | <input type="checkbox"/> Spain |
| <input type="checkbox"/> China - Shanghai | <input type="checkbox"/> Iran | <input type="checkbox"/> Sweden |
| <input type="checkbox"/> Cyprus | <input type="checkbox"/> Israel | <input type="checkbox"/> Switzerland |
| <input type="checkbox"/> Denmark | <input type="checkbox"/> Korea | <input type="checkbox"/> Taiwan |
| <input type="checkbox"/> Egypt | <input type="checkbox"/> Malaysia | <input type="checkbox"/> Thailand |
| <input type="checkbox"/> Finland | <input type="checkbox"/> New Zealand | <input type="checkbox"/> Turkey |
| <input type="checkbox"/> France | <input type="checkbox"/> Norway | <input type="checkbox"/> U.S.A. |
| <input type="checkbox"/> Germany | <input type="checkbox"/> Portugal | |

<div style="display: flex; align-items: center;">  <div style="margin-left: 10px;"> <h2 style="margin: 0;">WESTCAR</h2> <p style="margin: 0;">s.r.l.</p> <h3 style="margin: 0; font-style: italic;">ROTOFLUID</h3> </div> </div> <p style="margin-top: 10px;">WESTCAR s.r.l. Via Monte Rosa, 14 - 20149 MILANO (Italy) Tel. +39 02.76.11.03.19 r.a. - Fax +39 02.76.11.00.41 E-mail: info@westcar.it - www.westcar.it</p>	<p>Distributor</p> <div style="border: 1px solid black; height: 100px; width: 100%;"></div>
---	---